

3. OZONE

Ozone was first used for drinking water treatment in 1893 in the Netherlands. While being used frequently in Europe for drinking water disinfection and oxidation, it was slow to transfer to the United States. In 1987, the Los Angeles Aqueduct Filtration Plant was placed in service and now treats up to 600 mgd of drinking water. In 1991, approximately 40 water treatment plants each serving more than 10,000 people in the United States utilized ozone (Langlais et al., 1991). This number has grown significantly, with Rice (in press) reporting that as of April 1998, 264 operating plants in the United States use ozone. Most of these facilities are small: 149 plants are below 1 mgd.

Ozone is used in water treatment for disinfection and oxidation. Early application of ozone in the United States was primarily for non-disinfection purposes such as color removal or taste and odor control. However, since the implementation of the SWTR and proposal of the DBP rule, ozone usage for primary disinfection has increased in the United States.

3.1 Ozone Chemistry

Ozone exists as a gas at room temperature. The gas is colorless with a pungent odor readily detectable at concentrations as low as 0.02 to 0.05 ppm (by volume), which is below concentrations of health concern. Ozone gas is highly corrosive and toxic.

Ozone is a powerful oxidant, second only to the hydroxyl free radical, among chemicals typically used in water treatment. Therefore, it is capable of oxidizing many organic and inorganic compounds in water. These reactions with organic and inorganic compounds cause an ozone demand in the water treated, which should be satisfied during water ozonation prior to developing a measurable residual.

Ozone is sparingly soluble in water. At 20°C, the solubility of 100 percent ozone is only 570 mg/L (Kinman, 1975). While ozone is more soluble than oxygen, chlorine is 12 times more soluble than ozone. Ozone concentrations used in water treatment are typically below 14 percent, which limits the mass transfer driving force of gaseous ozone into the water. Consequently, typical concentrations of ozone found during water treatment range from <0.1 to 1mg/L, although higher concentrations can be attained under optimum conditions.

Basic chemistry research (Hoigné and Bader, 1983a and 1983b; Glaze et al., 1987) has shown that ozone decomposes spontaneously during water treatment by a complex mechanism that involves the generation of hydroxyl free radicals. The hydroxyl free radicals are among the most reactive oxidizing agents in water, with reaction rates on the order of 10^{10} - 10^{13} $M^{-1} s^{-1}$, approaching the diffusion control rates for solutes such as aromatic hydrocarbons, unsaturated compounds, aliphatic alcohols, and formic acid (Hoigné and Bader, 1976). On the other hand, the half-life of hydroxyl free radicals is on the order of microseconds, therefore concentrations of hydroxyl free radicals can never reach levels above 10^{-12} M (Glaze and Kang, 1988).

As shown in Figure 3-1 ozone can react by either or both modes in aqueous solution (Hoigné and Bader, 1977):

- Direct oxidation of compounds by molecular ozone ($O_{3(aq)}$).
- Oxidation of compounds by hydroxyl free radicals produced during the decomposition of ozone.

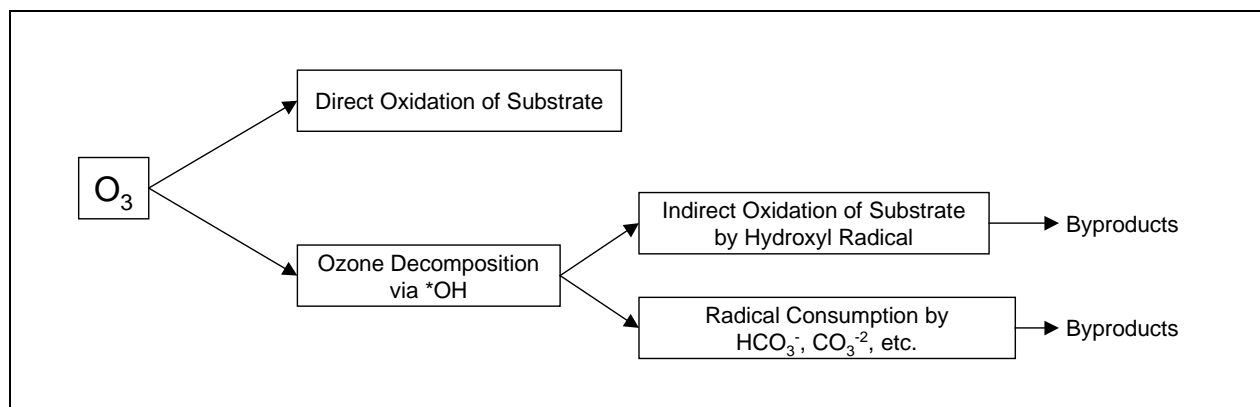

Figure 3-1. Oxidation Reactions of Compounds (Substrate) During Ozonation of Water

The two oxidation pathways compete for substrate (i.e., compounds to oxidize). The direct oxidation with aqueous ozone is relatively slow (compared to hydroxyl free radical oxidation) but the concentration of aqueous ozone is relatively high. On the other hand, the hydroxyl radical reaction is fast, but the concentration of hydroxyl radicals under normal ozonation conditions is relatively small. Hoigné and Bader (1977) found that:

- Under acidic conditions, the direct oxidation with molecular ozone is of primary importance; and
- Under conditions favoring hydroxyl free radical production, such as high pH, exposure to UV, or addition of hydrogen peroxide, the hydroxyl oxidation starts to dominate.

This latter mechanism is used in advanced oxidation processes such as discussed in Chapter 7, Peroxone, to increase the oxidation rates of substrates.

The spontaneous decomposition of ozone occurs through a series of steps. The exact mechanism and reactions associated have not been established, but mechanistic models have been proposed (Hoigné and Bader, 1983a and 1983b; Glaze, 1987). It is believed that hydroxyl radicals form as one of the intermediate products, and can react directly with compounds in the water. The decomposition of ozone in pure water proceeds with hydroxyl free radicals produced as an intermediate product of ozone decomposition, resulting in the net production of 1.5 mole hydroxyl free radicals per mole ozone.

In the presence of many compounds commonly encountered in water treatment, ozone decomposition forms hydroxyl free radicals. Ozone demands are associated with the following:

- Reactions with natural organic matter (NOM) in the water. The oxidation of NOM leads to the formation of aldehydes, organic acids, and aldo- and ketoacids (Singer, 1992).
- Organic oxidation byproducts. Organic oxidation byproducts are generally more amenable to biological degradation and can be measured as assimilable organic carbon (AOC) or biodegradable dissolved organic carbon (BDOC).
- Synthetic organic compounds (SOCs). Some SOCs can be oxidized and mineralized under favorable conditions. To achieve total mineralization, hydroxyl radical oxidation should usually be the dominant pathway, such as achieved in advanced oxidation processes.
- Oxidation of bromide ion. Oxidation of bromide ion leads to the formation of hypobromous acid, hypobromite ion, bromate ion, brominated organics, and bromamines (see Figure 3-2).
- Bicarbonate or carbonate ions, commonly measured as alkalinity, will scavenge the hydroxyl radicals and form carbonate radicals (Staehelin et al., 1984; Glaze and Kang, 1988). These reactions are of importance for advanced oxidation processes where the radical oxidation pathway is predominant.

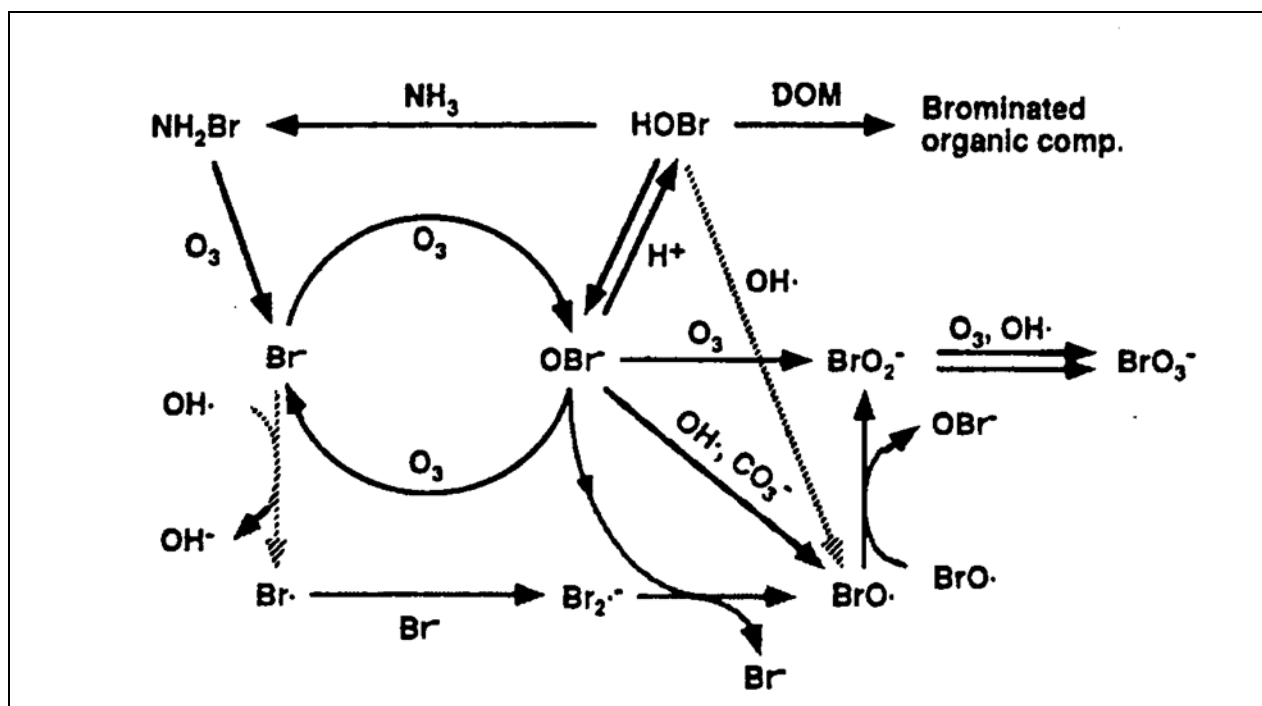

Source: Gunten and Hoigné, 1996.

Figure 3-2. Reaction of Ozone and Bromide Ion Can Produce Bromate Ion and Brominated Organics

3.2 Ozone Generation

3.2.1 Ozone Production

Because ozone is an unstable molecule, it should be generated at the point of application for use in water treatment. It is generally formed by, combining an oxygen atom with an oxygen molecule (O_2):

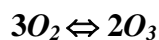

This reaction is endothermic and requires a considerable input of energy.

Schönbein (Langlais et < biblio >) first discovered synthetic ozone through the electrolysis of sulfuric acid. Ozone can be produced several ways, although one method, corona discharge, predominates in the ozone generation industry. Ozone can also be produced by irradiating an oxygen-containing gas with ultraviolet light, electrolytic reaction and other emerging technologies as described by Rice (1996).

Corona discharge, also known as silent electrical discharge, consists of passing an oxygen-containing gas through two electrodes separated by a dielectric and a discharge gap. Voltage is applied to the electrodes, causing an electron flowthrough across the discharge gap. These electrons provide the energy to disassociate the oxygen molecules, leading to the formation of ozone. Figure 3-3 shows a basic ozone generator.

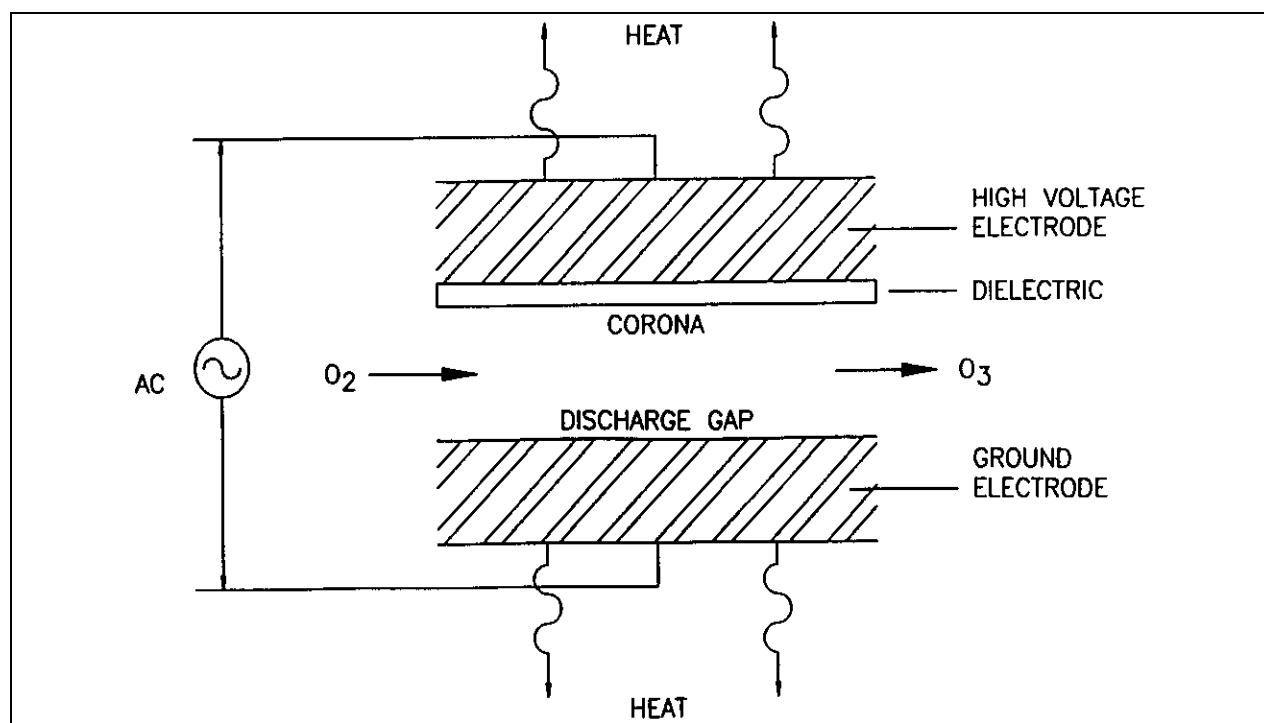

Figure 3-3. Basic Ozone Generator

3.2.2 System Components

As shown in Figure 3-4, ozone water treatment systems have four basic components: a gas feed system, an ozone generator, an ozone contactor, and an off-gas destruction system. The gas feed system provides a clean, dry source of oxygen to the generator. The ozone contactor transfers the ozone-rich gas into the water to be treated, and provides contact time for disinfection (or other reactions). The final process step, off-gas destruction, is required as ozone is toxic in the concentrations present in the off-gas. Some plants include an off-gas recycle system that returns the ozone-rich off-gas to the first contact chamber to reduce the ozone demand in the subsequent chambers. Some systems also include a quench chamber to remove ozone residual in solution.

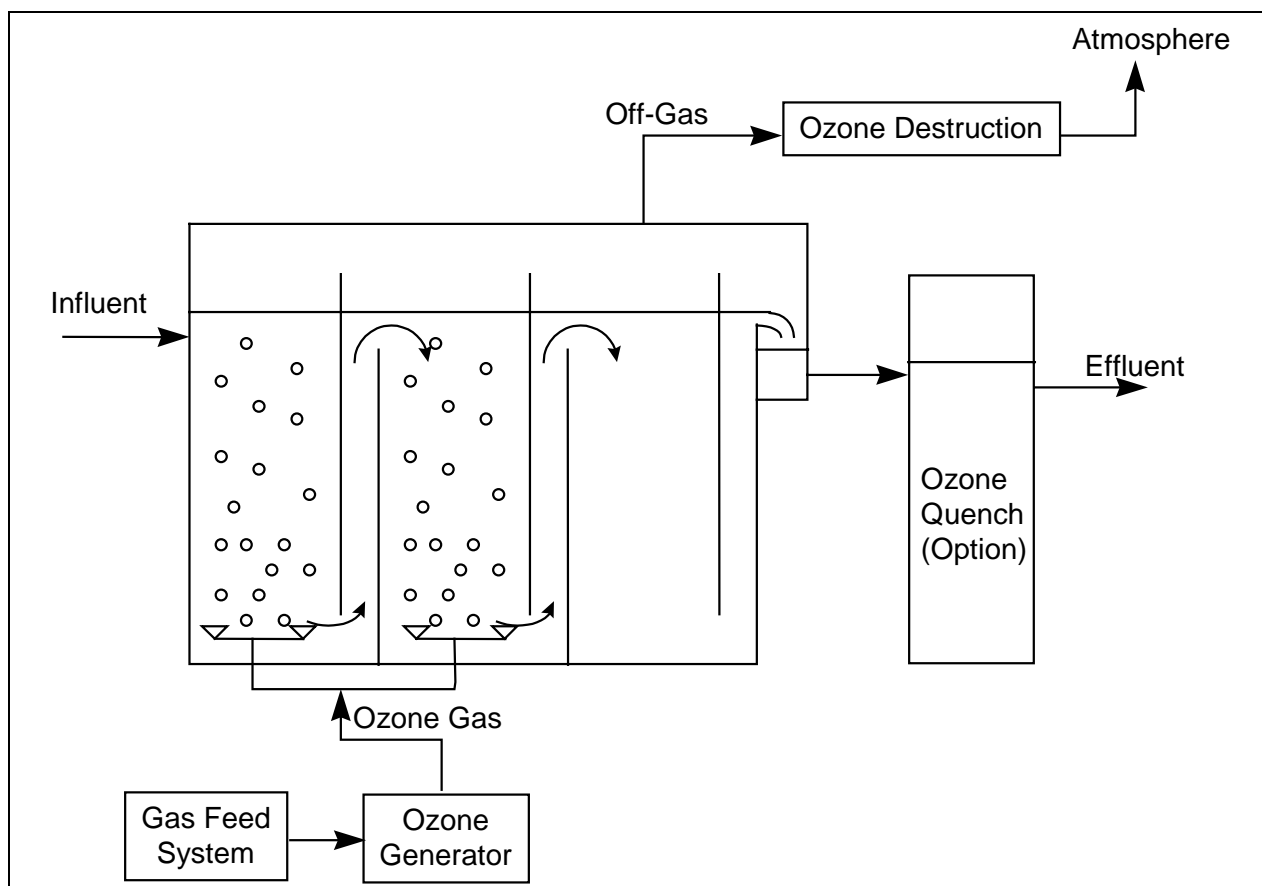

Figure 3-4. Simplified Ozone System Schematic

3.2.2.1 Gas Feed Systems

Ozone feed systems are classified as using air, high purity oxygen or mixture of the two. High purity oxygen can be purchased and stored as a liquid (LOX), or it can be generated on-site through either a cryogenic process, with vacuum swing adsorption (VSA), or with pressure swing adsorption (PSA). Cryogenic generation of oxygen is a complicated process and is feasible only in large systems. Pressure swing adsorption is a process whereby a special molecular sieve is used under pressure to

selectively remove nitrogen, carbon dioxide, water vapor, and hydrocarbons from air, producing an oxygen rich (80–95 percent O₂) feed gas. The components used in pressure swing adsorption systems are similar to high pressure air feed systems in that both use pressure swing molecular absorption equipment. Low pressure air feed systems use a heat reactivated desiccant dryer.

Oxygen Feed Systems - Liquid oxygen feed systems are relatively simple, consisting of a storage tank or tanks, evaporators to convert the liquid to a gas, filters to remove impurities, and pressure regulators to limit the gas pressure to the ozone generators.

Air Feed Systems - Air feed systems for ozone generators are fairly complicated as the air should be properly conditioned to prevent damage to the generator. Air should be clean and dry, with a maximum dew point of -60° C (-80° F) and free of contaminants. Air preparation systems typically consist of air compressors, filters, dryers, and pressure regulators. Figure 3-5 is a schematic of large scale air preparation system.

Particles greater than 1 µm and oil droplets greater than 0.05 µm should be removed by filtration (Langlais et al., 1991). If hydrocarbons are present in the feed gas, granular activated carbon filters should follow the particulate and oil filters. Moisture removal can be achieved by either compression or cooling (for large-scale system), which lowers the holding capacity of the air, and by desiccant drying, which strips the moisture from the air with a special medium. Desiccant dryers are required for all air preparation systems. Large or small particles and moisture cause arcing which damages generator dielectrics.

Typically, desiccant dryers are supplied with dual towers to allow regeneration of the saturated tower while the other is in service. Moisture is removed from the dryer by either an external heat source or by passing a fraction (10 to 30 percent) of the dried air through the saturated tower at reduced pressure. Formerly, small systems that require only intermittent use of ozone, a single desiccant tower is sufficient, provided that it is sized for regeneration during ozone decomposition time.

Air preparation systems can be classified by the operating pressure: ambient, low (less than 30 psig), medium, and high (greater than 60 psig) pressure. The distinguishing feature between low and high pressure systems is that high pressure systems can use a heatless dryer. A heatless dryer operates normally in the 100 psig range, rather than the 60 psig range. Rotary lobe, centrifugal, rotary screw, liquid ring, vane, and reciprocating compressors can be used in air preparation systems. Table 3-1 lists the characteristics of many of these types of compressors.

Reciprocating and liquid ring compressors are the most common type used in the United States, particularly in small systems, the former because the technology is so prevalent and the latter because liquid ring compressors do not need aftercoolers. Air receivers are commonly used to provide variable air flow from constant volume compressors. Oil-less compressors are used in modern systems to avoid hydrocarbons in the feed gas (Dimitriou, 1990).

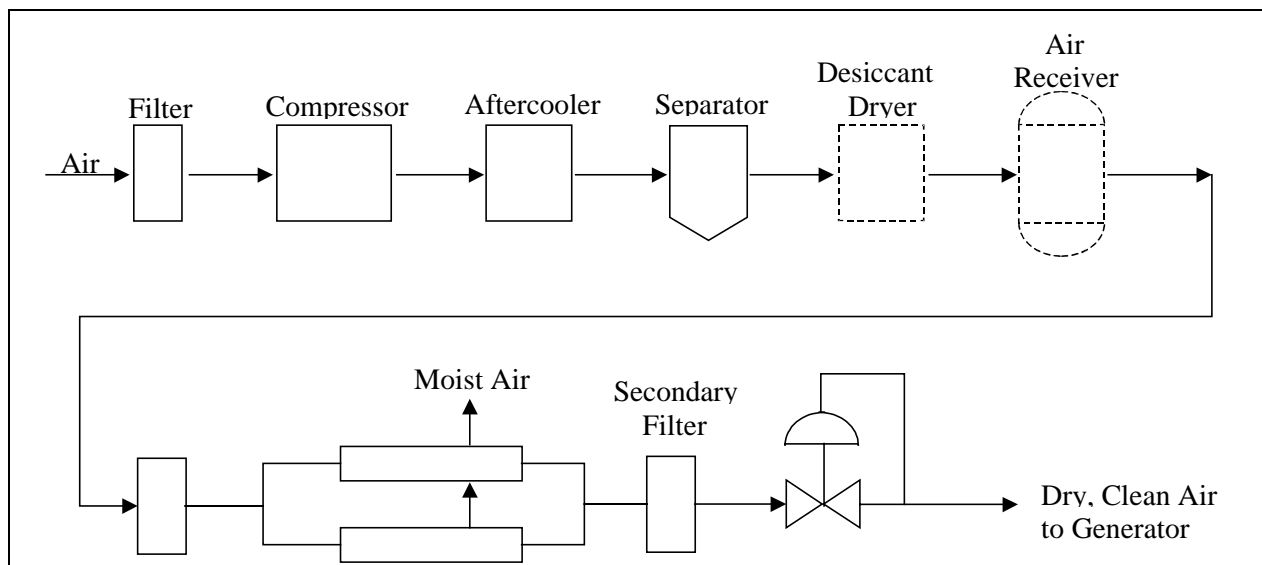

Figure 3-5. Schematic of an Air Preparation System

Table 3-1. Types of Compressors Used in Air Preparation Systems

Compressor Type	Pressure	Volume	Comments
Rotary lobe	Low – 15 psi	Constant or variable with unloading	Common in Europe
Centrifugal	30 – 100 psi depending on no. of stages	Variable, high volume	Medium efficiency, cost effective in high volumes
Rotary Screw	50 psi (single stage) to 100 psi (2 stage)	Variable with unloading	Slightly more efficient than rotary lobe, draws approximately 40% of full load power in unloaded state, available in non-lubricated design for larger capacities.
Liquid Ring	10–80 psi	Constant volume	Does not require lubrication or aftercooler, relatively inefficient, common in United States.
Vane	High - to 100 psi	Constant or variable	Relatively inefficient, not common in U.S.

Table 3-2 presents a comparison of the advantages and disadvantages of each gas feed system.

Table 3-2. Comparison of Air and High Purity Oxygen Feed Systems

Source	Advantages	Disadvantages
Air	<ul style="list-style-type: none"> • Commonly used equipment • Proven technology • Suitable for small and large systems 	<ul style="list-style-type: none"> • More energy consumed per ozone volume produced • Extensive gas handling equipment required • Maximum ozone concentration of 3-5%
Oxygen (general)	<ul style="list-style-type: none"> • Higher ozone concentration (8-14%) • Approximately doubles ozone concentration for same generator • Suitable for small and large systems 	<ul style="list-style-type: none"> • Safety concerns • Oxygen resistant materials required
LOX	<ul style="list-style-type: none"> • Less equipment required • Simple to operate and maintain • Suitable for small and intermediate systems • Can store excess oxygen to meet peak demands 	<ul style="list-style-type: none"> • Variable LOX costs • Storage of oxygen onsite (Fire Codes, i.e. safety concerns) • Loss of LOX in storage when not in use
Cryogenic Oxygen Generation	<ul style="list-style-type: none"> • Equipment similar to air preparation systems • Feasible for large systems • Can store excess oxygen to meet peak demands 	<ul style="list-style-type: none"> • More complex than LOX • Extensive gas handling equipment required • Capital intensive • Complex systems to operate and maintain

3.2.2.2 Ozone Generators

The voltage required to produce ozone by corona discharge is proportional to the pressure of the source gas in the generator and the width of the discharge gap. Theoretically, the highest yield (ozone produced per unit area of dielectric) would result from a high voltage, a high frequency, a large dielectric constant, and a thin dielectric. However, there are practical limitations to these parameters. As the voltage increases, the electrodes and dielectric materials are more subject to failure. Operating at higher frequencies produces higher concentrations of ozone and more heat requiring increased cooling to prevent ozone decomposition. Thin dielectrics are more susceptible to puncturing during maintenance. The design of any commercial generator requires a balance of ozone yield with operational reliability and reduced maintenance.

Two different geometric configurations for the electrodes are used in commercial ozone generators: concentric cylinders and parallel plates. The parallel plate configuration is commonly used in small generators and can be air cooled. Figure 3-6 shows the basic arrangement for the cylindrical configuration. The glass dielectric/high voltage electrode in commercial generators resembles a fluorescent light bulb and is commonly referred to as a “generator tube.”

Most of the electrical energy input to an ozone generator (about 85 percent) is lost as heat (Rice, 1996). Because of the adverse impact of temperature on the production of ozone, adequate cooling should be provided to maintain generator efficiency. Excess heat is removed usually by water

flowing around the stainless steel ground electrodes. The tubes are arranged in either a horizontal or vertical configuration in a stainless steel shell, with cooling water circulating through the shell.

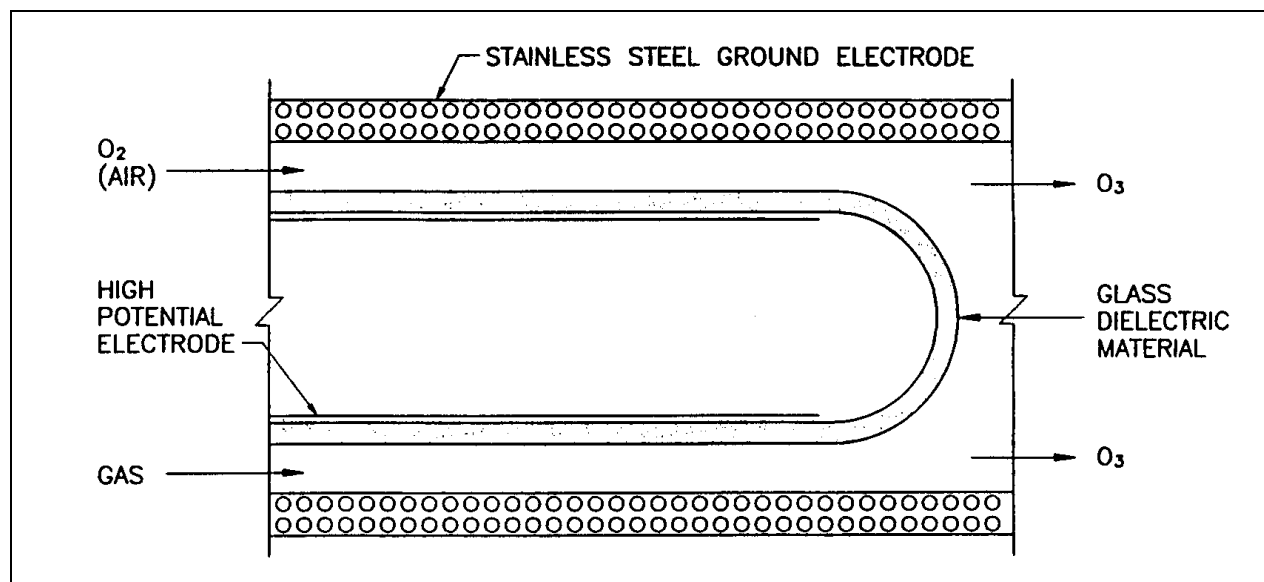

Figure 3-6. Cylindrical Electrode Schematic

Ozone generators are classified by the frequency of the power applied to the electrodes. Low frequency (50 or 60 Hz) and medium frequency (60 to 1,000 Hz) generators are the most common found in the water industry, however some high frequency generators are available. Table 3-3 presents a comparison of the three types of generators. Medium frequency generators are efficient and can produce ozone economically at high concentrations, but they generate more heat than low frequency generators and require a more complicated power supply to step up the frequency supplied by utility power. New installations tend to use medium or high frequency generators.

3.2.2.3 Ozone Contactors

Once ozone gas is transferred into water, the dissolved ozone reacts with the organic and inorganic constituents, including any pathogens. Ozone not transferred into the process water during contacting is released from the contactor as off-gas. Transfer efficiencies of greater than 80 percent typically are required for efficient ozone disinfection (DeMers and Renner, 1992).

Common ozone dissolution methods include:

- Bubble diffuser contactors;
- Injectors; and
- Turbine mixers.

Table 3-3. Comparison of Primary Characteristics of Low, Medium, and High Frequency Ozone Generators

Characteristic	Low Frequency (50 - 60 Hz)	Medium Frequency (up to 1,000 Hz)	High Frequency (> 1,000 Hz)
Degree of Electronics Sophistication	low	high	high
Peak Voltages	19.5	11.5	10
Turndown Ratio	5:1	10:1	10:1
Cooling Water Required (gal/lb of ozone produced)	0.5 to 1.0	0.5 to 1.5	0.25 to 1
Typical Application Range	< 500 lb/day	to 2,000 lb/day	to 2,000 lb/day
Operating Concentrations			
wt - % in air	0.5 to 1.5%	1.0 to 2.5%+	1.0 to 2.5%+
wt - % in oxygen	2.0 to 5.0%	2 to 12%	2 to 12%
Optimum Ozone Production (as a proportion of total generator capacity)	60 to 75%	90 to 95%	90 to 95%
Optimum Cooling Water Differential	8° to 10°F	5° to 8°F	5° to 8°F
Power Required (kW-h/lb O ₃)	air feed: 8 to 12 O ₂ feed: 4 to 6	air feed: 8 to 12 O ₂ feed: 4 to 6	air feed: 8 to 12 O ₂ feed: 4 to 6
Air Feed System Power Requirements (kW-h/lb O ₃)	5 to 7	5 to 7	5 to 7

Source: Adapted from Rice, 1996, with modifications.

Bubble Diffuser Contactors

The bubble diffuser contactor is commonly used for ozone contacting in the United States and throughout the world (Langlais et al., 1991). This method offers the advantages of no additional energy requirements, high ozone transfer rates, process flexibility, operational simplicity, and no moving parts. Figure 3-7 illustrates a typical three stage ozone bubble diffuser contactor. This illustration shows a countercurrent flow configuration (ozone and water flowing in opposite directions), an alternating cocurrent/countercurrent arrangement, and a cocurrent flow configuration (ozone and water flowing in the same direction). Also, the number of stages can vary from two to six for ozone disinfection, with the majority of plants using two or three chambers for contacting and reaction (Langlais et al., 1991).

Bubble diffuser contactors are typically constructed with 18 to 22 ft water depths to achieve 85 to 95 percent ozone transfer efficiency. Since all the ozone is not transferred into the water, the contactor chambers are covered to contain the off-gas. Off-gas is routed to an ozone destruct unit, usually catalysts, thermal, or thermal/catalysts.

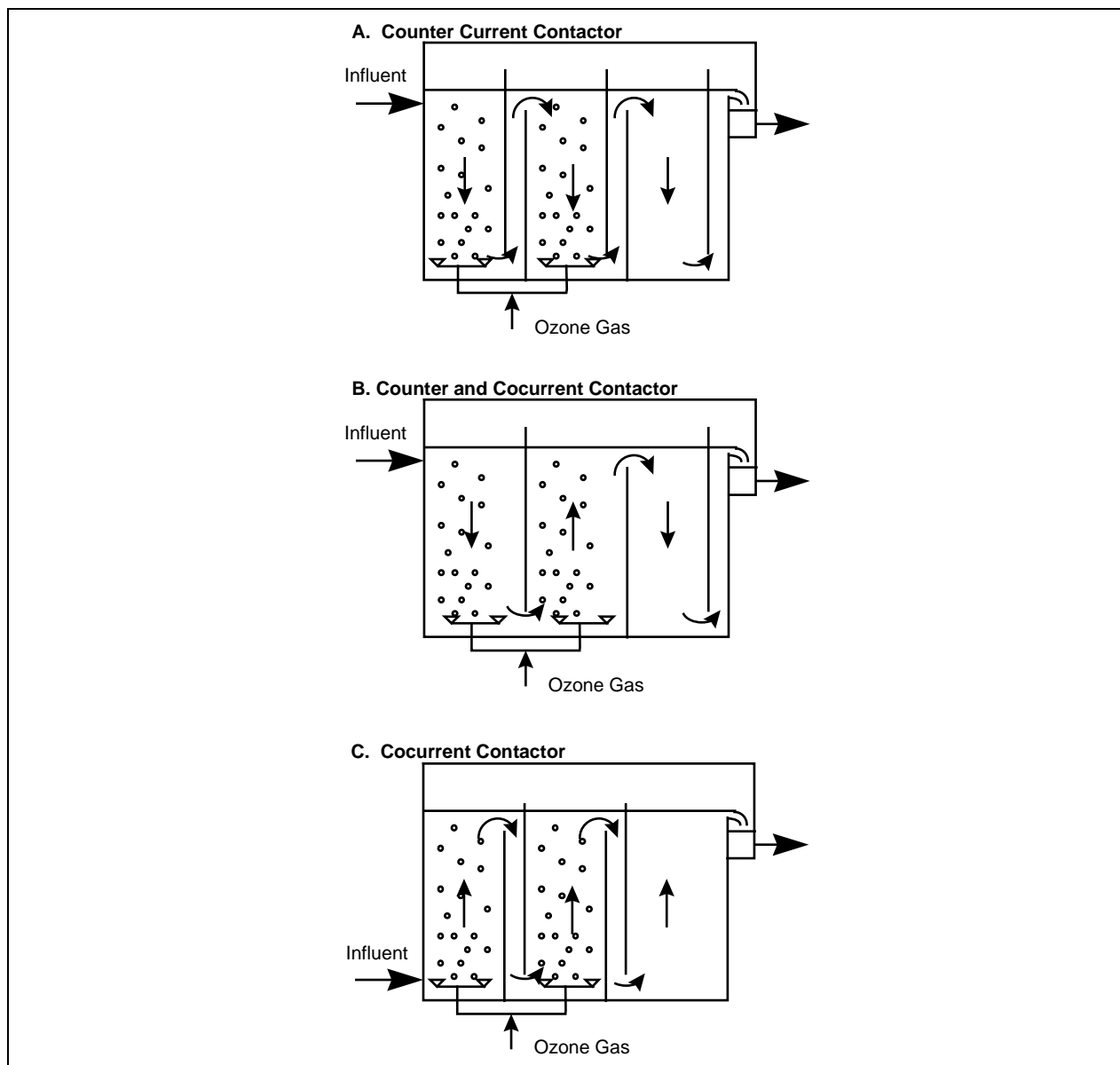

Figure 3-7. Ozone Bubble Contactor

Bubble diffuser contactors use ceramic or stainless steel diffusers that are either rod-type or disc-type to generate bubbles. Design considerations for these diffusers (Renner et al., 1988) include:

- Gas flow range of 0.5 to 4.0 scfm;
- Maximum headloss of 0.5 psig;
- Permeability of 2 to 15 cfm/ft²/in of diffuser thickness; and porosity of 35 to 45 percent.

The configuration of the bubble diffuser contactor structure should best be designed to provide plug flow hydraulics. This configuration will minimize the overall volume of the contactor while still

meeting the CT requirements for the system. Contactor volume is determined in conjunction with the applied ozone dosage and estimated residual ozone concentration to satisfy the disinfection CT requirement.

Table 3-4 summarizes the advantages and disadvantages of the bubble diffuser contactor (Langlais et al., 1991). Also, diffuser pore clogging can be a problem when ozone dosages are intermittent and/ or when iron and manganese oxidation is required. Channeling of bubbles is dependent on the type of diffusers used and the spacing between diffusers.

Table 3-4. Bubble Diffuser Contactor Advantages and Disadvantages

Advantages	Disadvantages
No moving parts	Deep contact basins
Effective ozone transfer	Vertical channeling of bubbles
Low hydraulic headloss	Maintenance of gaskets and piping.
Operational simplicity	

Injector Dissolution

The injector contacting method is commonly used in Europe, Canada, and the United States (Langlais et al., 1991). Ozone is injected into a water stream under negative pressure, which is generated in a venturi section, pulling the ozone into the water stream. In many cases, a sidestream of the total flow is pumped to a higher pressure to increase the available vacuum for ozone injection. After the ozone is injected into this sidestream, the sidestream containing all the added ozone is combined with the remainder of the plant flow under high turbulence to enhance dispersion of ozone into the water. Figure 3-8 illustrates typical in-line and sidestream ozone injection systems.

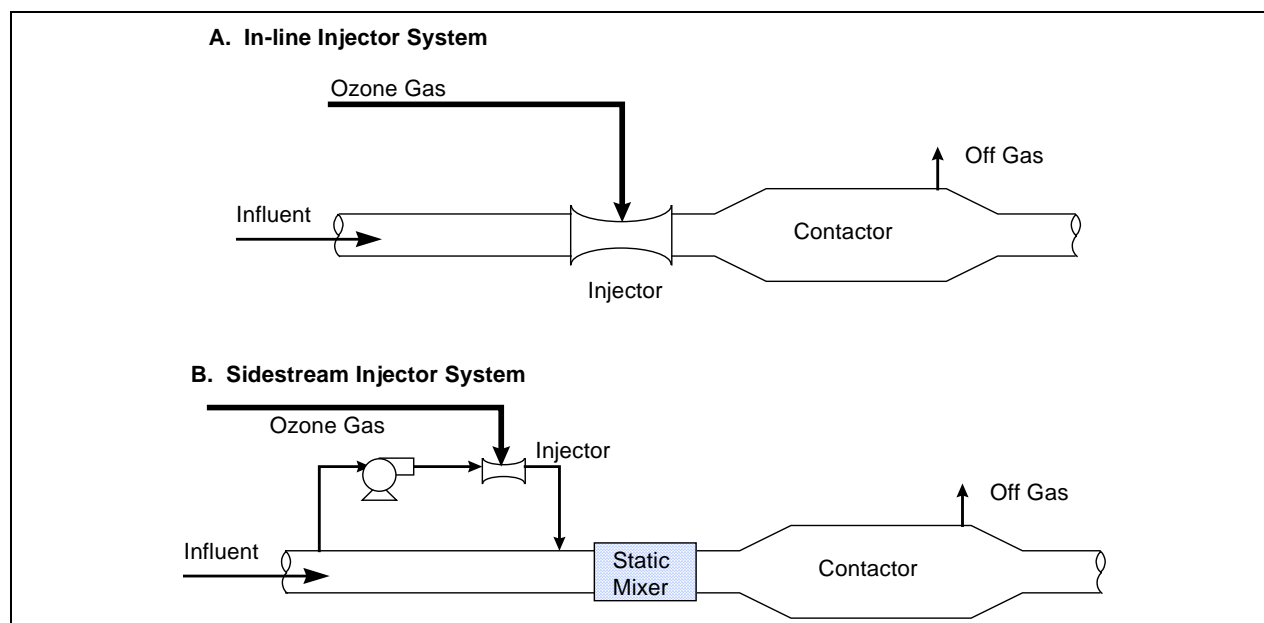

Figure 3-8. Sidestream Ozone Injection System

The gas to liquid ratio is a key parameter used in the design of injector contacting systems. This ratio should be less than 0.067 cfm/gpm to optimize ozone transfer efficiency (Langlais et al., 1991). Meeting this criterion typically requires relatively low ozone dosages and ozone gas concentrations greater than 6 percent by weight (DeMers and Renner, 1992). High concentration ozone gas can be generated using a medium-frequency generator and/or liquid oxygen as the feed gas.

To meet the CT disinfection requirements, additional contact time is required after the injector, typically in a plug flow reactor. The additional contact volume is determined in conjunction with the applied ozone dosage and estimated residual ozone concentration to satisfy the disinfection CT requirement.

Table 3-5 summarizes the advantages and disadvantages of injection contacting (Langlais et al., 1991).

Table 3-5. Injection Contacting Advantages and Disadvantages

Advantages	Disadvantages
Injection and static mixing have no moving parts	Additional headloss (energy usage) due to static mixers which may require pumping
Very effective ozone transfer	Turndown capability limited by injection system
Contactors depth less than bubble diffusion	More complex operation and high cost.

Turbine Mixer Contactors

Turbine mixers are used to feed ozone gas into a contactor and mix the ozone with the water in the contactor. Figure 3-9 illustrates a typical turbine contactor. The illustrated turbine mixer design shows the motor located outside the basin, allowing for maintenance access. Other designs use a submerged turbine.

Ozone transfer efficiency for turbine mixers can be in excess of 90 percent. However, the power required to achieve this efficiency is 2.2 to 2.7 kW-hr of energy per lb of ozone transferred (Dimitriou, 1990).

Turbine mixing basins vary in water depth from 6 to 15 ft, and dispersion areas vary from 5 to 15 ft (Dimitriou, 1990). Again, as with injector contacting, sufficient contact time may not be available in the turbine basin to meet disinfection CT requirements; consequently additional contact volume may be required.

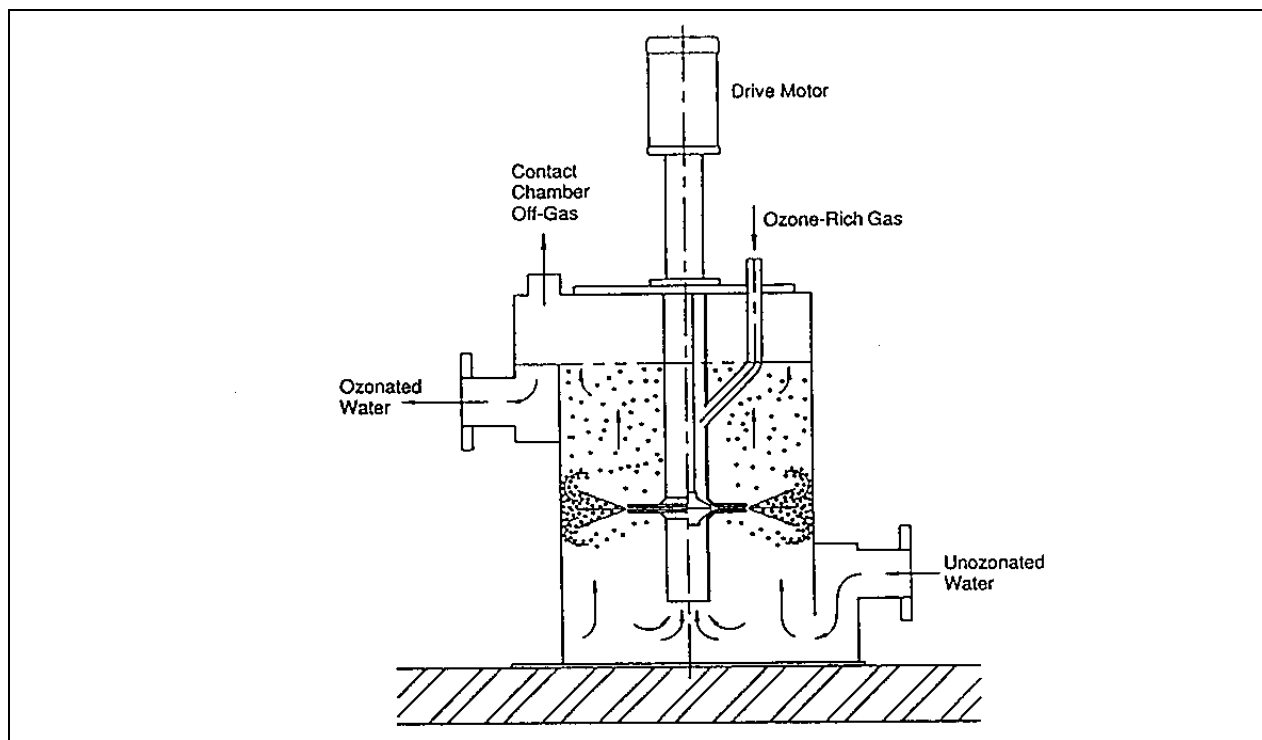

Figure 3-9. Turbine Mixer Ozone Contactor

Table 3-6 summarizes advantages and disadvantages for the turbine mixer contactor (Langlais et al., 1991).

Table 3-6. Turbine Mixer Contactor Advantages and Disadvantages

Advantages	Disadvantages
Ozone transfer is enhanced by high turbulence resulting in small bubble size	Require energy input
Contactor depth less than bubble diffusion	Constant gas flow rate should be maintained, reducing ozone transfer efficiency
Aspirating turbines can draw off-gas from other chambers for reuse	Maintenance requirements for turbine and motor
Eliminates diffuser clogging concerns	

3.2.2.4 Off-gas Destruction Systems

The concentration of ozone in the off-gas from a contactor is usually well above the fatal concentration. For example, at 90 percent transfer efficiency, a 3 percent ozone feed stream will still contain 3,000 ppm of ozone in the off-gas. Off-gas is collected and the ozone converted back to oxygen prior to release to the atmosphere. Ozone is readily destroyed at high temperature ($> 350^{\circ}\text{C}$ or by a catalyst operating above 100°C) to prevent moisture buildup. The off-gas destruct unit is designed to reduce the concentration to 0.1 ppm of ozone by volume, the current limit set by OSHA

for worker exposure in an eight hour shift. A blower is used on the discharge side of the destruct unit to pull the air from the contactor, placing the contactor under a slight vacuum to ensure that no ozone escapes.

3.2.2.5 Instrumentation

Instrumentation should be provided for ozone systems to protect both personnel and the equipment. Gas phase ozone detectors should be provided in spaces such as generator rooms where ozone gas may be and personnel are routinely present. An ozone detector is also needed on the outlet from the off-gas destruct unit to ensure the unit is working properly. These units should be interlocked with the ozone generator controls to shut down the ozone generation system should excess ozone be detected. A dew point detector on the feed gas supply just upstream of an ozone generator is required to protect the generator from moisture in the feed gas (when air is the feed gas). Flow switches on the cooling water supply are needed to protect the generator from overheating and a pressure switch to prevent over pressurization.

Other instrumentation can be used to monitor and control the ozone process, although manual control is adequate for small systems, but most small systems are designed to operate automatically, particularly in remote areas. Ozone monitors can be used in conjunction with process flow meters to match ozone dose to process demands and control ozone generation. Sophisticated control schemes can be implemented to minimize the cost of dosing with ozone and reduce operator attention requirements. Many systems include residual monitoring at various points in the contactor to maintain a desired ozone residual and prevent energy-wasting overdosing.

3.2.3 Operation and Maintenance

Even though ozone systems are complex, using highly technical instruments, the process is highly automated and very reliable, requiring only a modest degree of operator skill and time to operate an ozone system. Maintenance on generators requires skilled technicians. If trained maintenance staff are not available at the plant, this work can be done by the equipment manufacturer. Some facilities, such as the 600 mgd Los Angeles Aqueduct Filtration Plant, use plant mechanics to perform generator and facilities maintenance. Therefore, backup units are usually installed. Generators should be checked daily when in operation. After a shutdown, dry air or oxygen should be allowed to flow through the generator to ensure that any moisture has been purged prior to energizing the electrodes. At initial start up and after long down times, this process may take up to 12 hours and usually longer when air is the feed gas. As an alternative, a small flow of dry air can be passed through the generator continuously when it is in standby mode to maintain the dry condition.

Filters and desiccant in air preparation systems should be changed periodically, with the frequency depending on the quality of the inlet air and the number of hours in operation. Compressors require periodic service, depending on the type and operating time. LOX tanks should be periodically pressure tested. Piping and contact chambers should be inspected periodically to check for leaks and corrosion.

Dielectric tubes should be periodically cleaned. This operation should be performed when the generator efficiency drops 10-15 percent. Cleaning the tubes is a delicate operation as the tubes are fragile and expensive. Adequate space should be provided for the cleaning operation and for storage of spare tubes.

3.3 Primary Uses and Points of Application of Ozone

3.3.1 Primary Uses of Ozone

Ozone is used in drinking water treatment for a variety of purposes including:

- Disinfection;
- Inorganic pollutant oxidation, including iron, manganese, and sulfide;
- Organic micropollutant oxidation, including taste and odor compounds, phenolic pollutants, and some pesticides; and
- Organic macropollutant oxidation, including color removal, increasing the biodegradability of organic compounds, DBP precursor control, and reduction of chlorine demand.

3.3.1.1 Disinfection

Ozone is a powerful oxidant able to achieve disinfection with less contact time and concentration than all weaker disinfectants, such as chlorine, chlorine dioxide, and monochloramine (Demers and Renner, 1992). However, ozone can only be used as a primary disinfectant since it cannot maintain a residual in the distribution system. Thus, ozone disinfection should be coupled with a secondary disinfectant, such as chlorine, chloramine, or chlorine dioxide for a complete disinfection system.

3.3.1.2 Iron and Manganese Oxidation

Ozone will oxidize iron and manganese, converting ferrous (2+) iron into the ferric (3+) state and 2+ manganese to the 4+ state. The oxidized forms will precipitate as ferric hydroxide and manganese hydroxide (AWWA, 1990). The precise chemical composition of the precipitate will depend on the nature of the water, temperature, and pH. The ozone dose required for oxidation is 0.43 mg/mg iron and 0.88 mg/mg manganese (Langlais et al., 1991). Iron oxidizes at a pH of 6-9 but manganese is more effective at a pH of around 8. Also, over-ozonation has no effect on iron, but will resolubilize manganese, which then should be reduced to manganese dioxide downstream.

3.3.1.3 Oxidation of Taste and Odor Compounds

Ozone is used to oxidize/destroy taste and odor-causing compounds because many of these compounds are very resistant to oxidation. Suffet et al. (1986) confirmed that ozone is an effective oxidant for use in taste and odor treatment. They found ozone doses of 2.5 to 2.7 mg/L and 10 minutes of contact time (ozone residual of 0.2 mg/L) significantly reduced taste and odors in the

specific waters they tested. Most early U.S. water plants (i.e., 1940-1986) installed ozonation specifically for taste and odor removal.

3.3.1.4 DBP Precursor Control

Early work on oxidation of DBP precursors seemed to indicate that the effects of ozonation, prior to chlorination, were quite site-specific and unpredictable (Umphries et al., 1979). The key variables that seem to determine ozone's effect are dose, pH, alkalinity, and, above all, the nature of the organic material. At low pH levels, precursor destruction by ozone is quite effective; however, above some critical pH, ozone actually is less effective and in fact sometimes increases the amount of chlorination byproduct precursors. For most humic substances this critical pH is 7.5, which is the approximate level at which decomposition of ozone to hydroxyl free radicals increases rapidly, thus increasing organic oxidation rates. Therefore, the implications that at lower pH (approximately 6-7), at which molecular ozone predominates over the hydroxyl free radical, the initial THM precursor by-products are different in nature than those formed by the hydroxyl free radicals oxidized at higher pH levels. This is logical in light of the greater oxidation potential of the hydroxyl free radical over that of ozone.

As alkalinity increases, it has a beneficial effect on THM formation potential (THMFP) (Langlais et al., 1991). This is because alkalinity scavenges any hydroxyl free radicals formed during ozonation, leaving molecular ozone as the sole oxidant, which is only capable of oxidizing organic precursors to a lower oxidation sequence than does the hydroxyl free radical. Given neutral pH and moderate levels of bicarbonate alkalinity, THMFP level reductions of 3 to 20 percent have been shown at ozone doses ranging from 0.2 to 1.6 mg ozone per mg carbon (Singer et al., 1989; Georgeson and Karimi, 1988).

3.3.1.5 Increase Organic Biodegradation

Ozone can be effective in partially oxidizing organics in the water to biodegradable compounds that can be removed by biological filtration (Demers and Renner, 1992). This partial oxidation gives rise to lower molecular weight organics that are more easily biodegradable. This increase in the biodegradable fraction of organic carbon occurs as a result of moderate to high levels of ozonation. These ozone levels are typical of the doses commonly applied for disinfection.

3.3.1.6 Coagulation and Filtration Improvement

Ozone has been reported by some to improve coagulation and filtration efficiency (Gurol and Pidotella, 1993; Farvardin and Collins, 1990; Reckhow et al., 1993; Stolarik and Christie, 1997). However, others have found no improvement in filter effluent turbidity due to ozonation (Tobiason et al., 1992; Hildebrand et al., 1986). Prendiville (1986) collected data from a large water treatment plant showing that pre-ozonation was more effective than pre-chlorination to reduce filter effluent turbidities. The cause of the improved coagulation is not clear, but several possibilities have been offered (Reckhow et al., 1986), including:

- Oxidation of organic compounds into more polar forms; and
- Oxidation of metals ions to yield insoluble complexes, such as ferric iron complexes.

3.3.2 Points of Application

The typical locations for feeding ozone in a water treatment plant are at the head of the treatment plant (raw water) pre-ozonation and after sedimentation.

Raw water quality and turbidity and ozone demand (the amount of ozone required for all oxidation requirements of the water) can be used to assess how to use ozone in the treatment process. Table 3-7 lists the criteria for selecting ozone feed points based on these two parameters. By moving the ozonation process further downstream after sedimentation, the ozone demand and production of byproducts are reduced. The advantage of placing ozone ahead of filtration is that biodegradable organics produced during ozonation can be removed by subsequent biological activity in the filters.

Table 3-7. Criteria for Selecting Ozone Feed Points for Small Systems

Raw Water Quality	Ozone Feed Point(s)	Special Considerations
Category I Turbidity < 10 NTU Ozone Demand < 1mg/L	Raw Water or After Sedimentation	Low ozone demand. Low disinfection byproducts. Low biodegradable organics.
Category II Turbidity > 10 NTU Ozone Demand < 1mg/L	After Sedimentation	Low ozone demand. High inorganic particulate. Low biodegradable organics.
Category III Turbidity < 10 NTU Ozone Demand > 1mg/L	Raw Water and/or After Sedimentation	High ozone demand Disinfection byproducts Biodegradable organics formation
Category IV Turbidity > 10 NTU Ozone Demand > 1mg/L	After Sedimentation and After First Stage Filtration, if necessary	High ozone demand Disinfection byproducts Biodegradable organics formation

Source: DeMers and Renner, 1992.

For high quality water with direct filtration, the only practical ozone feed point is the raw water.

Category II (Table 3-7) water is characterized by low ozone demand and high turbidity. This water quality indicates the presence of inorganic material, such as clay or silt particles. For ozone to be most effective for Category II water disinfection, it should be added after either pre-sedimentation or conventional sedimentation.

Raw water with low turbidity and high ozone demand (Category III, Table 3-7) contains dissolved constituents, not suspended, that contribute to a high ozone demand. An example of this type of water is a ground water containing bromide ion, iron, manganese, color, or organics. For this water quality, ozone can be added to either the raw water or after sedimentation. If the water contains organic constituents that become more biodegradable by ozonation, a biological treatment step (see

Section 3.3.4) may be required. The presence of oxidizable organic constituents or bromide ion will generate disinfection byproducts upon ozonation.

Category IV (Table 3-7) water would be considered the most difficult water to treat with ozone due to its high turbidity and high ozone demand. An example of this water quality is surface water containing high concentrations of organic material and inorganic particles. The most effective use of ozone for this water quality is after sedimentation and possibly after filtration. If the water has an extremely high ozone demand, dual ozone feed points may be required to achieve disinfection goals, because the presence of large amounts of organic material may require a biological treatment step and may generate disinfection byproducts.

3.3.3 Impact on Other Treatment Processes

Ozonation does have an impact on other processes at the water treatment facility. The impacts of ozone addition include the following:

- The use of ozone generates biodegradable organic matter (BOM) that can result in biological growth which may also increase corrosion rates in distribution systems if not removed by biologically active filtration. When ozonation is placed before biological filters, it can impact the filters by increasing biological growth and increasing backwash frequency.
- Ozone is a strong oxidant that reacts with other oxidants, such as chlorine, chlorine dioxide, and monochloramine.
- Ozone oxidation of iron and manganese generates insoluble oxides that should be removed by sedimentation or filtration. These insoluble oxides also impact the filters by increasing load on the filters and increasing backwash frequency.
- Using pre- and/or internal ozone on most raw waters reduces the subsequent chlorine, chlorine dioxide, or monochloramine demand of the finished water so as to allow a stable chlorine-compound residual to be maintained at a much lower level.

The reader is referred to EPA's *Simultaneous Compliance Guidance Document* (expected to be available in 1999) for additional information regarding the interaction between oxidants and other treatment processes.

3.3.4 Biologically Active Filtration

Ozonation typically increases the biodegradability of NOM in water because many large organic molecules are converted into smaller organic molecules that are readily biodegradable. This increase in biodegradable dissolved organic carbon (BDOC) can lead to accelerated bacterial growth and regrowth in the distribution system if not removed in the treatment plant. LeChevallier et al. (1992) found that AOC levels less than 100 ppb may be necessary to control excessive bacterial regrowth in the distribution system if not removed in the treatment plant.

When ozonation is placed upstream of filtration, and environmental conditions such as dissolved oxygen, pH, and temperature are favorable, microbiological activity is increased in the filter and BDOC/AOC removal is enhanced. Ozone addition not only increases the biodegradability of the

dissolved organics, but also introduces large amounts of oxygen to the water, thus, creating an excellent environment for biological growth on the filter media. The advantages of biologically active filtration (Price, 1994) include the following which are all being met in most U.S. plants using ozone:

- Production of a biologically stable water that does not promote excessive bacterial growth and regrowth in the distribution system.
- Removal of NOM that can serve as precursors to byproduct formation as a result of residual disinfection with free or combined chlorine.
- Ozone oxidation as a primary disinfectant prior to biologically active filtration reduces the BDOC concentration in finished water, thus reducing chances of regrowth.
- Reduction of the residual disinfectant demand of the product water so that proposed regulations limiting the maximum disinfectant residual can be met.
- Removal or control of ozonation byproducts.

Biological activity can be supported on slow sand, rapid rate, and GAC media because these media provide a surface for bacteria to attach. Factors such as available surface area, hydraulic loading rate, contact time, availability of nutrients, temperature, and others will determine the performance and BDOC removal efficiency. Biomass develops to higher levels on GAC because of the rougher surface characteristics than on anthracite and sand.

3.3.4.1 Slow Sand Filters

Ozone addition prior to slow sand filtration can increase the efficiency of TOC removal by about 35 percent (Rachwal et al., 1988; Zabel, 1985). Ozone addition can also increase the efficiency of BDOC removal with slow sand filters (Eighmy et al., 1991; Malley et al., 1993).

3.3.4.2 Rapid Rate Filters

Research in the area of biologically active rapid rate filters has focused on the reduction of assimilable organic carbon (AOC) instead of BDOC. While studies have shown rapid rate filtration, employing either sand or dual media lowers AOC levels following ozonation, AOC does not measure all the BDOC. AOC measures only that portion of the BDOC that is more easily assimilable or more easily biodegradable under specific laboratory conditions by two specific microorganisms. Research data shows that biodegradation of AOC can occur in rapid rate filters. The data should be viewed with caution, since the more slowly biodegradable DOC, not measured by AOC, may be passing through rapid rate filters.

3.3.4.3 Granular Activated Carbon

GAC is made biologically active by the deliberate introduction of sufficient dissolved oxygen to water just before passing through GAC columns (Katz, 1980). The high surface area and long retention time in GAC provide an ideal environment to enhance biological growth.

Although ozone actually increases the amount of BDOC, the efficiency of subsequent biodegradation on GAC can be such that the BDOC in GAC effluent is lower than the BDOC in the ozone influent (Langlais et al., 1991). The degree to which biodegradable DOC is removed by ozone/GAC depends upon the process conditions of temperature, amount of BDOC, and the GAC column loading rate, measured by empty bed contact time (EBCT). For example, with an influent BDOC of 0.65 mg C/L and a 10 minute EBCT, one would expect an effluent BDOC of 0.25 mg C/L. The effluent BDOC then could be lowered by either:

- Adding ozone, which would increase the GAC influent BDOC and, therefore, lower the effluent BDOC; or
- Adding more GAC or decreasing the loading rate, which would extend the EBCT and lower the effluent BDOC (Billen et al., 1985, as cited in Langlais et al., 1991).

Huck et al. (1991) reported results from AOC profiles measured in a pilot treatment plant. The plant treated Saskatchewan River water and included coagulation, flocculation, and sedimentation prior to ozonation. Following ozonation, the water was filtered through a dual media (anthracite-sand) filter followed by GAC adsorption. The results demonstrate:

- Variable AOC removal through coagulation, flocculation, and sedimentation (80 percent to zero);
- Increased AOC after ozonation;
- AOC removal through dual media filtration improving at lower hydraulic loading rates and filtered effluent AOC often less than raw water AOC, but highly variable; and
- AOC levels after GAC were low, almost always below raw water AOC concentrations and adsorption appears to contribute to some immediate AOC removal.

3.3.5 Pathogen Inactivation and Disinfection Efficacy

Ozone has a high germicidal effectiveness against a wide range of pathogenic organisms including bacteria, protozoa, and viruses. Because of its high germicidal efficiency, ozone can be used to meet high inactivation required by water treatment systems with or without filters. However, ozone cannot be used as a secondary disinfectant because the ozone residual decays too rapidly. The ozone disinfection efficiency is not affected by pH (Morris, 1975), although because of hydroxyl free radicals and rapid decay, efficiency is the same but more ozone should be applied at high pH to maintain “C”.

3.3.6 Inactivation Mechanisms

Inactivation of bacteria by ozone is attributed to an oxidation reaction (Bringmann, 1954; Chang, 1971). The first site to be attacked appears to be the bacterial membrane (Giese and Christensen, 1954) either through the glycoproteins or glycolipids (Scott and Leshner, 1963) or through certain amino acids such as typtophan (Goldstein and McDonagh, 1975). In addition, ozone disrupts enzymatic activity of bacteria by acting on the sulfhydryl groups of certain enzymes. Beyond the cell membrane and cell wall, ozone may act on the nuclear material within the cell. Ozone has been found to affect both purines and pyrimidines in nucleic acids (Giese and Christensen, 1954; Scott and Leshner, 1963).

The first site of action for virus inactivation is the virion capsid, particularly its proteins (Cronholm et al., 1976 and Riesser et al., 1976). Ozone appears to modify the viral capsid sites that the virion uses to fix on the cell surfaces. High concentrations of ozone dissociate the capsid completely. One researcher found that the mechanism of ozone inactivation of bacteriophage f2 ribonucleic acid (RNA) included releasing RNA from the phage particles after the phage coat was broken into many pieces (Kim et al., 1980). This finding suggests that ozone breaks the protein capsid, thereby liberating RNA and disrupting adsorption to the host pili. Further, the naked RNA may be secondarily inactivated by ozone at a rate less than that for RNA within the intact phage. The mechanism for inactivation of deoxyribonucleic acid (DNA) bacteriophage T4 has been found to be quite similar to RNA inactivation: ozone attacks the protein capsid, liberates the nucleic acid, and inactivates the DNA (Sproul et al., 1982). In contrast, more recent work on the tobacco mosaic virus (TMV) shows that ozone has a specific effect on RNA. Ozone was found to attack both the protein coat and RNA. The damaged RNA cross-links with amino acids of the coat protein subunits. The authors concluded that TMV loses its infectivity because of its loss of protein coating.

Microscopic observation of inactivation of trophozoites of *Naegleria* and *Acanthamoeba* showed that they were rapidly destroyed and the cell membrane was ruptured (Perrine et al., 1984). Perrine and Langlais showed that ozone affect the plugs in *Naegleria gruberi* cysts (Langlais and Perrine, 1984). Depending on the ozonation conditions, these plugs were completely removed or were partially destroyed. It has been speculated that ozone initially affects the *Giardia muris* cysts wall and makes it more permeable (Wickramanayake, 1984c). Subsequently, aqueous ozone penetrates into the cyst and damages the plasma membranes, additional penetration of ozone eventually affects the nucleus, ribosomes, and other ultrastructural components.

3.3.7 Disinfection Parameters

Hoigné and Bader demonstrated that the rate of decomposition of ozone is a complex function of temperature, pH, and concentration of organic solutes and inorganic constituents (Hoigné and Bader, 1975, and 1976). The following sections describe the effects that pH, temperature, and suspended matter have on the reaction rate of ozone and pathogen inactivation.

The ability to maintain a high aqueous ozone concentration is critical from a regulatory disinfection compliance standpoint. This means that factors that accelerate ozone decomposition are undesirable for inactivation because the ozone residual dissipates faster and therefore reduces the CT credit, requiring a corresponding increase in the ozone applied, thus increasing cost.

3.3.7.1 pH

Studies have indicated that pH has little effect on the ability of dissolved ozone residuals to inactivate acid-fast bacteria, such as *Mycobacteria* and *Actinomycetes* (Farooq, 1976). A slight decrease has been found in the virucidal efficacy of ozone residuals as pH decreased (Roy, 1979). However, the opposite effect was observed by Vaughn et al. (1987) (cited in Hoff, 1986). Changes in disinfection efficacy with variations in pH appear to be caused by the ozone decomposition rate. Ozone decomposition occurs faster in higher-pH aqueous solutions and forms various types of oxidants with differing reactivities (Langlais et al., 1991). Tests carried out at constant ozone residual concentration and different pH values showed that the degree of microorganism inactivation remained virtually unchanged (Farooq et al., 1977). More recent studies have indicated decreased virus inactivation by ozone at alkaline pH (pH 8 to 9) for poliovirus 1 (Harakeh and Butler, 1984) and rotaviruses SA-11 and Wa (Vaughn et al., 1987).

Inactivation of *Giardia muris* cysts was found to improve when the pH increased from 7 to 9 (Wickramanayake, 1984a). This phenomenon was attributed to the possible changes in cyst chemistry making it easier for ozone to react with the cyst constituents at the higher pH levels. However, the same study found that inactivation of *Naegleria gruberi* cysts was slower at a pH 9 than at lower pH levels, thereby indicating that pH effects are organism-specific.

3.3.7.2 Temperature

As temperature increases, ozone becomes less soluble and less stable in water (Katzenelson et al., 1974); however, the disinfection and chemical oxidation rates remain relatively stable. Studies have shown that although increasing the temperature from 0 to 30°C can significantly reduce the solubility of ozone and increases its decomposition rate, temperature has virtually no effect on the disinfection rate of bacteria (Kinman, 1975). In other words, the disinfection rate was found to be relatively independent of temperature at typical water treatment plant operating temperatures despite the reduction in solubility and stability at higher temperatures.

3.3.7.3 Suspended Matter

Ozone inactivation of viruses and bacteria contained in aluminum floc (in the size range comparable to those that could typically escape filtration) was not reduced at floc turbidity levels of 1 and 5 NTU (Walsh et al., 1980). This study demonstrated that the microorganisms received no protection from the aluminum floc. Similar results have been obtained for poliovirus 1, coxsackie virus A9, and *E. coli* associated with bentonite clay (Boyce et al., 1981). However, adsorption of the f2 bacteriophage at 1 and 5 NTU of bentonite clay was found to retard the rate of inactivation of ozone (Boyce et al., 1981).

In some instances, river waters heavily polluted with organic matter were ozonated, and the results indicated a degradation of large organic molecules into fragments more easily metabolized by microorganisms. This fragmentation coupled with the inability of ozone to maintain an active concentration in the distribution system, has led to increased slime growth and, consequently, water quality deterioration during distribution (Trojan and Hanson, 1989).

3.3.8 Inactivation of Microorganisms

The following sections contain a description of the disinfection efficiency of ozone in terms of bacteria, virus, and protozoa inactivation.

3.3.8.1 Bacterial Inactivation

Ozone is very effective against bacteria. Studies have shown the effect of small concentrations of dissolved ozone (i.e., 0.6 µg/L) on *E. coli*. (Wuhrmann and Meyrath, 1955) and *Legionella pneumophila* (Domingue, et al., 1988). *E. coli*. levels were reduced by 4 logs (99.99 percent removal) in less than 1 minute with a ozone residual of 9 µg/L at a temperature of 12°C. *Legionella pneumophila* levels were reduced by greater than 2 logs (99 percent removal) within a minimum contact time of 5 minutes at a ozone concentration of 0.21 mg/L. Results similar to those obtained for *E. coli*. have been found for *Staphylococcus* sp. and *Pseudomonas fluorescens* inactivation. *Streptococcus faecalis* required a contact time twice as long with the same dissolved ozone concentration, and *Mycobacterium tuberculosis* required a contact time six times as long for the same reduction level as *E. coli*.

In regard to vegetative bacteria, *E. coli* is one of the most sensitive types of bacteria. Furthermore, significant difference has been found among all the Gram-negative bacillae, including *E. coli* and other pathogens such as *Salmonella*, which are all sensitive to ozone inactivation. whereas the Gram-positive cocci (*Staphylococcus* and *Streptococcus*), the Gram-positive bacillae (*Bacillus*), and the *Mycobacteria* are the most resistant forms of bacteria. Sporular bacteria forms are always far more resistant to ozone disinfection than vegetative forms (Bablon, et al., 1991), but all are easily destroyed by relatively low levels of ozone.

3.3.8.2 Protozoa Inactivation

Protozoan cysts are much more resistant to ozone and other disinfectants than vegetative forms of bacteria and viruses. *Giardia lamblia* has a sensitivity to ozone that is similar to the sporular forms of *Mycobacteria*. Both *Naegleria* and *Acanthamoeba* cysts are much more resistant to ozone (and all other disinfectants) than *Giardia* cysts. (Bablon et al., 1991). CT products for 99 percent inactivation of *Giardia lamblia* and *N. gruberi* at 5°C were 0.53 and 4.23 mg • min/L, respectively (Wickramanayake et al., 1984a and 1984b). Data available for inactivation of *Cryptosporidium* oocysts, suggest that among protozoans, this microorganism is more resistant to ozone (Peeters et al., 1989; Langlais et al., 1990). One study found that *Cryptosporidium* oocysts are approximately 10 times more resistant to ozone than *Giardia* (Owens et al., 1994).

3.3.8.3 Virus Inactivation

Typically, viruses are more resistant to ozone than vegetative bacteria but less resistant than sporular forms of *Mycobacteria* (Bablon, et al., 1991). The most sensitive forms of viruses are phages, and there seems to be little difference between the polio- and coxsackie viruses. The sensitivity of human rotavirus to ozone was determined to be comparable to that of *Mycobacteria* and polio- and coxsackie viruses (Vaughn et al., 1987).

Keller et al. (1974) studied ozone inactivation of viruses by using both batch tests and pilot plant data. Inactivation of poliovirus 2 and coxsackie virus B3 was more than 3 logs (99.9 percent) in the batch tests with an ozone residual of 0.8 mg/L and 1.7 mg/L and a contact time of 5 minutes. Greater than 5 log (99.999 percent) removal of coxsackie virus was achieved in the pilot plant with an ozone dosage of 1.45 mg/L, which provided an ozone residual of 0.28 mg/L in lake water.

3.3.8.4 CT Curves for *Giardia Lamblia*

CT values shown in Figure 3-9 are based on disinfection studies using in vitro excystation of *Giardia lamblia*. CT values obtained at 5°C and pH 7 were used as the basis for deriving the CT values at other temperatures. A safety factor of 2 has been applied to the values shown in Figure 3-9.

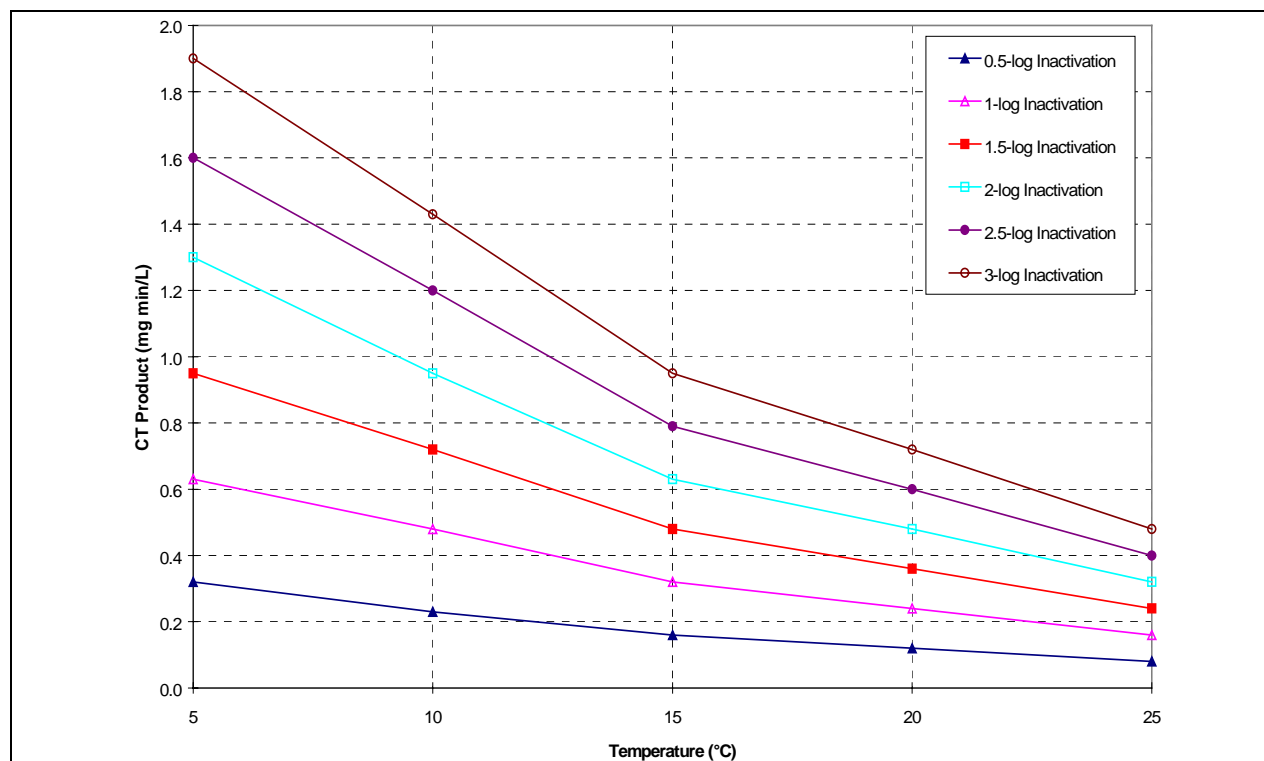

Figure 3-9. CT Values for Inactivation of *Giardia* Cysts by Ozone (pH 6 to 9)

CT values shown in Figure 3-10 for achieving 2-log inactivation of viruses were determined by applying a safety factor of 3 to data obtained from a previous study on poliovirus 1 (Roy et al., 1982). CT values for 3 and 4-log removal were derived by applying first order kinetics and assuming the same safety factor of 3. Data obtained at a pH of 7.2 was assumed to apply for the pH range of 6 to 9.

Several research groups have investigated the efficiency of ozone for *Cryptosporidium* oocyst inactivation. Table 3-8 summarizes CT values obtained for 99 percent inactivation of *Cryptosporidium* oocysts. Results indicate that ozone is one of the most effective disinfectants for controlling *Cryptosporidium* (Finch, et al., 1994) and that *Cryptosporidium muris* may be slightly more resistant to ozonation than *Cryptosporidium parvum* (Owens et al., 1994). A wide range of CT values has been reported for the same inactivation level, primarily because of the different methods of *Cryptosporidium* measurements employed and pH, temperature, and above all, ozonation conditions.

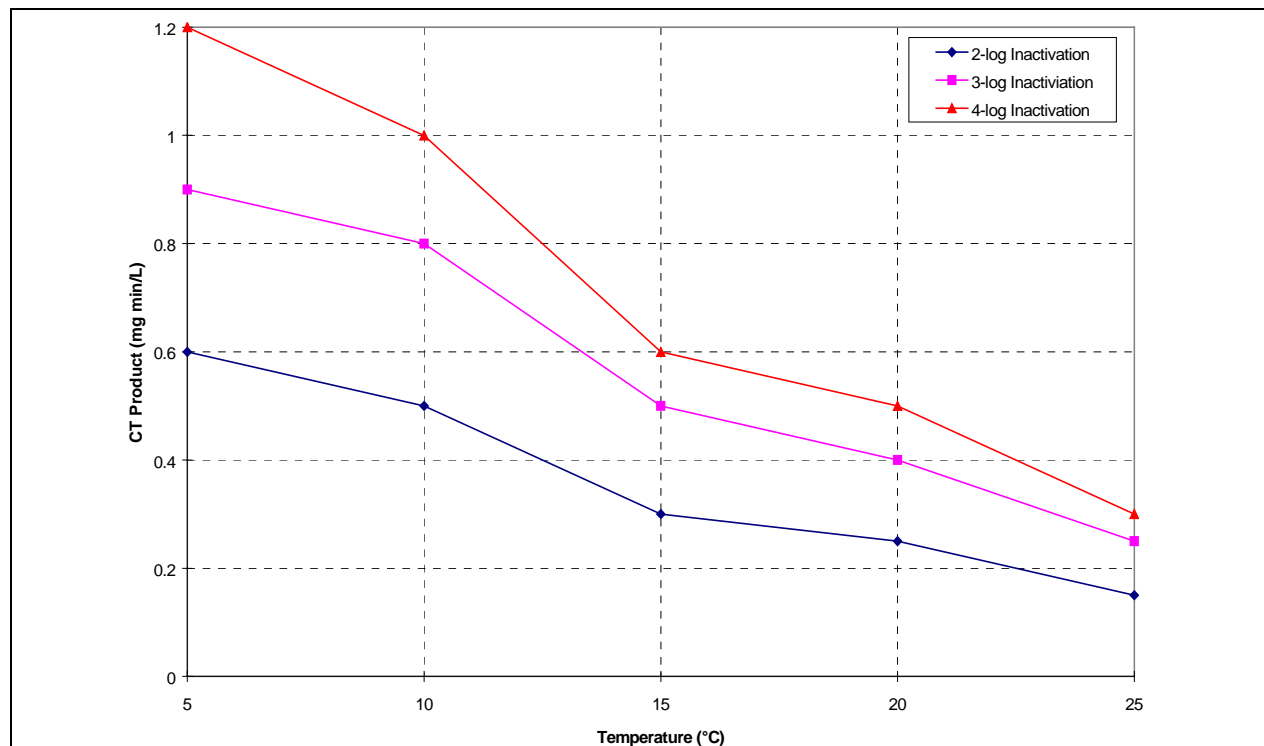

Figure 3-10. CT Values for Inactivation of Viruses by Ozone (pH 6 to 9)

Table 3-8. Summary of Reported Ozonation Requirements for 99 Percent Inactivation of *Cryptosporidium* Oocysts

Species	Ozone protocol	Ozone residual (mg/L)	Contact time (min)	Temperature (°C)	CT (mg.min/L)	Reference
<i>C. baileyi</i>	Batch liquid, modified batch ozone	0.6 & 0.8	4	25	2.4 - 3.2	Langlais et al., 1990
<i>C. muris</i>	Flow through contactor, continuous gas			22 - 25	7.8	Owens et al., 1994
<i>C. parvum</i>	Batch liquid, batch ozone	0.50	18	7	9.0	Finch et al., 1993
		0.50	7.8	22	3.9	
<i>C. parvum</i>	Batch liquid, batch ozone	0.77	6	Room	4.6	Peeters et al., 1989
		0.51	8		4	
<i>C. parvum</i>	Batch liquid, continuous gas	1.0	5 & 10	25	5 - 10	Korich et al., 1990
<i>C. parvum</i>	Flow through contactor, continuous gas			22 - 25	5.5	Owens et al., 1994

Ozone dose and contact time (CT) requirements for the inactivation of *Cryptosporidium* oocysts in drinking water when using ozone has not been established similar to the CT values for viruses and *Giardia* cyst inactivation. Inactivation requirements (log removals) for *Cryptosporidium* oocysts have not been established. In addition, as shown in Table 3-8, the CT requirements reported in the literature vary from study to study which adds uncertainty to design CT requirements for specific applications or regulatory needs.

3.4 Ozonation Disinfection Byproducts

Ozone does not form halogenated DBPs (TTHMs and HAA5s) when participating in oxidation/reduction reactions with NOM but it does form a variety of organic and inorganic byproducts. Table 3-9 and Figure 3-11 show the principal known byproducts associated with ozonation. However, if bromide ion is present in the raw water halogenated DBPs may be formed. These brominated DBPs appear to pose a greater health risk than non-brominated DBPs.

Table 3-9. Principal Known Byproducts of Ozonation

Disinfectant Byproducts	
Aldehydes	Aldo- and Ketoacids
Formaldehyde	Pyruvic acid
Acetaldehyde	Brominated Byproducts*
Glyoxal	Bromate ion
Methyl Glyoxal	Bromoform
Acids	Brominated acetic acids
Oxalic acid	Bromopicrin
Succinic acid	Brominated acetonitriles
Formic acid	Others
Acetic acid	Hydrogen peroxide

*Brominated byproducts are produced only in waters containing bromide ion

Source: Singer, 1992.

Although ozone is an effective oxidant and disinfectant, it should not be relied upon as a secondary disinfectant to maintain a residual in the distribution system. Monochloramine is attractive for this purpose because it produces little to no halogenated DBPs. Chlorine is a candidate for secondary disinfectant but the ozonated water may actually produce either more or less DBPs following the addition of free chlorine depending on the nature of the organic material following ozonation unless biologically active filtration precedes the addition of chlorine. The principal benefit of using ozone for controlling DBP formation is that it allows free chlorine to be applied later in the treatment process after precursors have been removed and at lower doses, thereby reducing DBPFP.

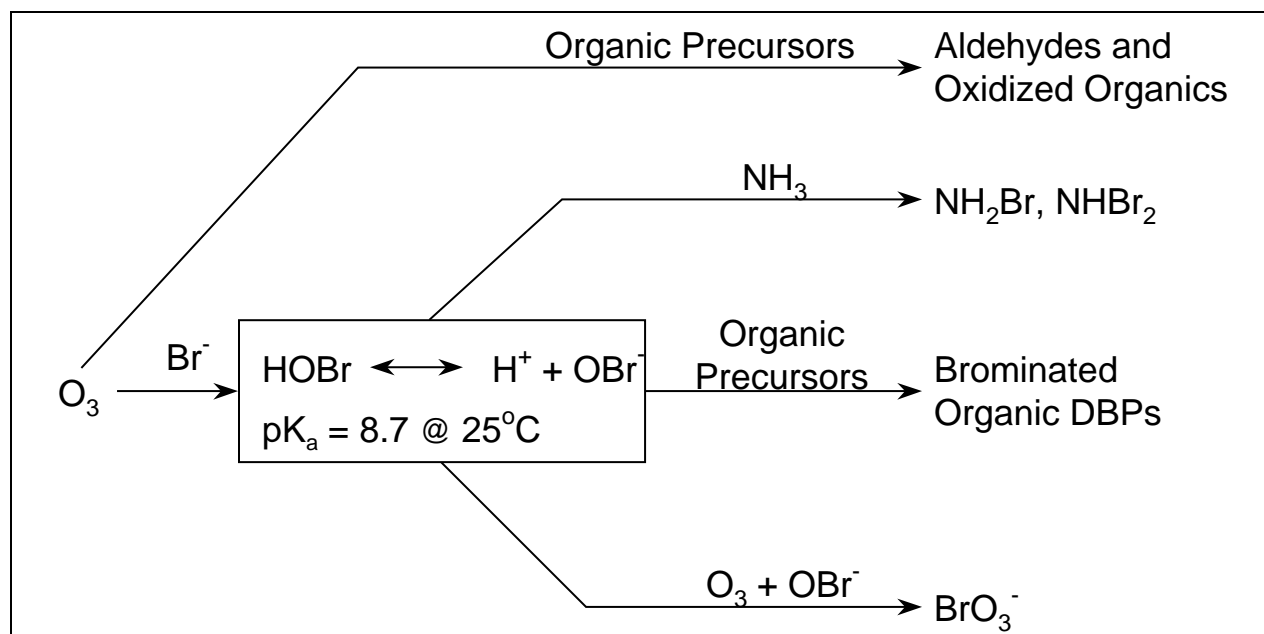
**Figure 3-11. Principal Reactions Producing Ozone Byproducts**

Application of a secondary disinfectant following ozonation requires special consideration for potential interaction between disinfectants. For example, chloral hydrate formation has been

observed when using chlorine as a secondary disinfectant with ozone (McKnight and Reckhow, 1992; Logsdon et al., 1992). The ozonation byproduct of acetaldehyde is a known precursor for chloral hydrate, a byproduct of chlorination. Enhancement of chloral hydrate has not been observed when monochloramine is applied as the secondary disinfectant, or if biologically active filtration is used following ozonation and prior to chlorination (Singer, 1992). Chloropicrin formation from free chlorine appears to be enhanced by pre-ozonation (Hoigné and Bader, 1988) in the absence of biologically active filtration prior to addition of chlorine.

Byproducts such as aldehydes, ketones, acids, and others will be formed upon ozonation of water. The primary aldehydes that have been measured are: formaldehyde, acetaldehyde, glyoxal, and methyl glyoxal (Glaze et al., 1991). Total aldehyde concentration in drinking water disinfected with ozone range from less than 5 µg/L to 300 µg/L, depending on the TOC concentration and the applied ozone to organic carbon ratio (Van Hoof et al., 1985; Yamada and Somiya, 1989; Glaze et al., 1989a; Krasner et al., 1989; Glaze et al., 1991; LeLacheur et al., 1991). Aldehydes with higher molecular weights have also been reported (Glaze et al., 1989b). Other organic byproducts of ozonation are indicated in Table 3-9

Ozonation of a source water containing bromide ion can produce brominated byproducts, the brominated analogues of the chlorinated DBPs. Song et al. (1997) found that bromate ion formation is an important consideration for waters containing more than 0.10 mg/L bromide ion. These brominated byproducts include bromate ion, bromoform, the brominated acetic acids and acetonitriles, bromopicrin, and cyanogen bromide (if ammonia is present). An ozone dose of 2 mg/L produced 53 µg/L of bromoform and 17 µg/L of dibromoacetic acid in a water containing 2 mg/L of bromide ion (McGuire et al., 1990). Ozonation of the same water spiked with 2 mg/L bromide ion showed cyanogen bromide formation of 10 µg/L (McGuire et al., 1990). Furthermore, ozone may react with the hypobromite ion to form bromate ion (Amy and Siddiqui, 1991; Krasner et al., 1993), a probable human carcinogen (Regli et al., 1992). Bromate ion concentrations in ozonated water up to 60 µg/L have been reported (Amy and Siddiqui, 1991; Krasner et al., 1993). Note that the amount of bromide ion incorporated into the measured DBPs accounts for only one-third of the total raw water bromide ion concentration. This indicates that other brominated DBPs exist that are not yet identified (Krasner et al., 1989; MWDSC and JMM, 1992). Figure 3-12 shows the major pathways for bromate ion formation.

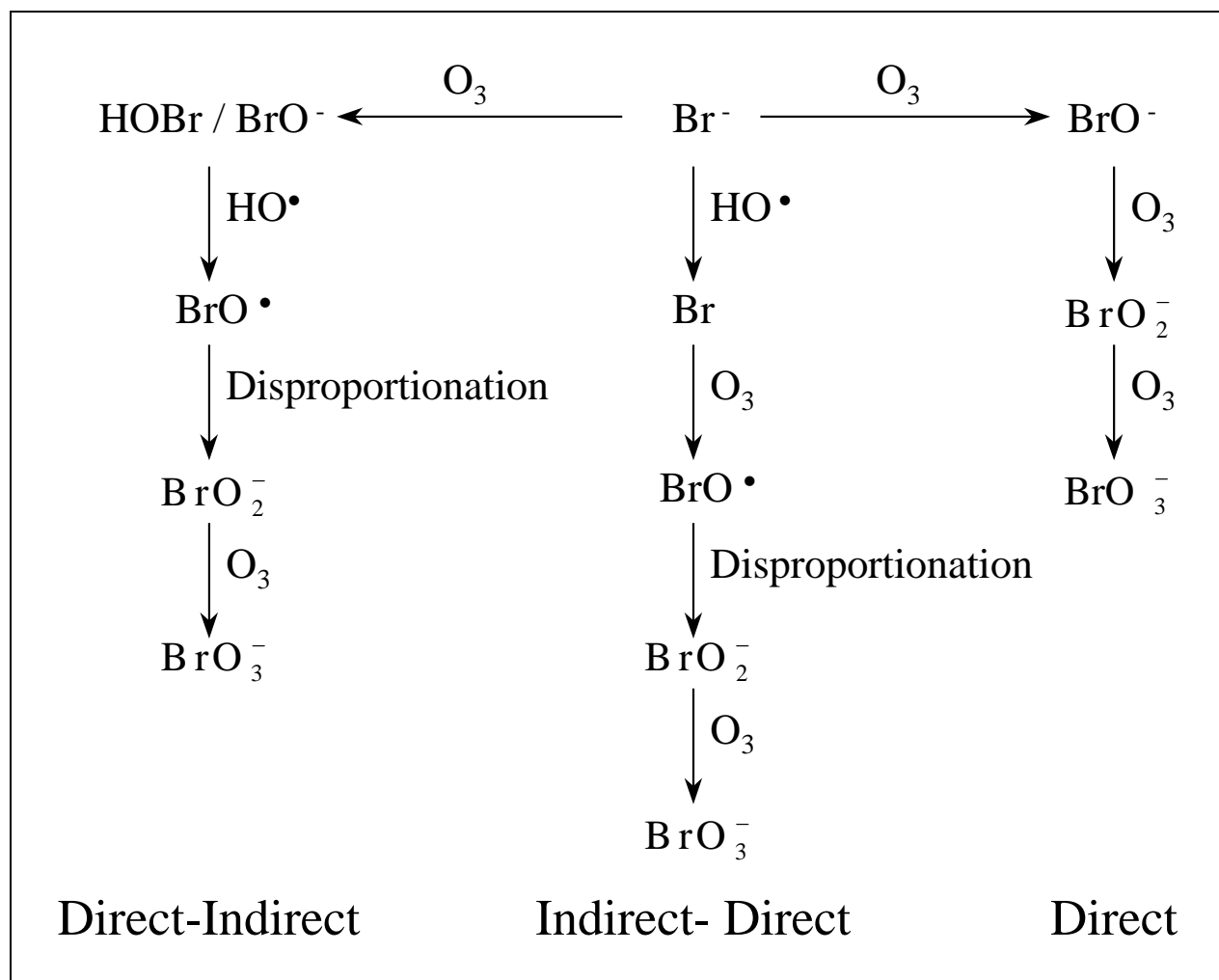

Source: Song et al., 1997.

Figure 3-12. Main Pathways of Bromate Ion Formation when Ozone Reacts with Bromide Ion

3.4.1 Ozone Byproduct Control

The primary factors affecting the speciation and concentrations of brominated byproducts are pH and the ozone-to-bromide ion and TOC-to-bromide ion ratios (Singer, 1992). Bromate ion formation can be controlled by ozonation at acidic pH values of which hypobromous acid dominates over the now absent hypobromite ion (Haag and Hoigné, 1984; Amy and Siddiqui, 1991; Krasner et al., 1993). Conversely, under alkaline pH conditions, ozone can oxidize the hypobromous acid further to produce bromate ion. At low pH values, the brominated organic byproducts are favored, while at greater pH values, bromate ion formation is favored. Therefore, the application of ozone may be limited for source waters containing bromide ion. Bromate ion formation can be controlled by lowering the ambient bromide ion concentration, lowering the ozone residual, and lowering the ozonation pH. The addition of ammonia with ozonation to form bromamines reduces the formation of both bromate ion and organic byproducts (Amy and Siddiqui, 1991; MWDSC and JMM, 1992). However, ammonia can act as a nutrient for nitrifying bacteria.

The organic acid and aldehyde byproducts of ozonation discussed above appear to be readily biodegradable and are a component of the assimilable organic carbon (AOC) or biodegradable organic carbon (BDOC). Ozonation increases the BOM by oxidation. Therefore, if water disinfected with ozone is coupled with a biologically active process (i.e., biological active carbon), removal of these biodegradable byproducts can be reduced. The use of biologically active filters, maintained by discontinuing the application of a disinfectant to the filters, has been shown to successfully remove aldehydes and other compounds representing a portion of the BDOC in a water (Bablon et al., 1988; Rittman, 1990; Reckhow et al., 1992). See Section 3.3.4 for a detailed discussion on biological active filters.

A recent study has shown that bromate ion and brominated organics can be controlled during ozonation by the following techniques (Song et al., 1997):

- Low pH decreases bromate ion formation while increasing brominated organic formation;
- Ammonia addition with short ozone contact time decreases both bromate ion and brominated organic formation;
- Hydrogen peroxide decreases brominated organic formation and may increase or decrease bromate ion formation, depending on other water quality parameters; and
- Low ozone DOC ratio leads to low bromate ion and brominated organic formation.

3.5 Status of Analytical Methods

During operation of an ozonation system it is necessary to analyze for ozone in both the liquid and gas phase to determine the applied ozone dose, ozone transfer efficiency and (for primary disinfection) residual ozone level. The gas stream exiting the ozone generator is monitored for ozone content to determine the applied ozone dose. The off-gas exiting the ozone contactor is monitored to determine the amount of ozone transferred to the liquid phase in the contactor and to calculate the ozone transfer efficiency. The disinfected water exiting the ozone contactor is monitored for residual ozone to ensure that CT values are met.

In addition, the ambient air in any ozone generating or handling room and ozone destruct off-gas are monitored for ozone concentration to protect workers in the event of leakages or destruct system failure.

3.5.1 Monitoring of Gas Phase Ozone

Points in an ozone treatment system where gas-phase ozone is monitored include:

- Ozone generator output;
- Contactor off-gas;
- Ozone destruct off-gas; and

- Ambient air in ozone process areas.

The range of ozone concentrations to be measured in the gas phase varies from less than 0.1 ppm by volume ($0.2 \text{ mg/m}^3 \text{ NTP}$) in ambient air and ozone destruct off-gas, to 1 to 2 percent ($10 \text{ g/m}^3 \text{ NTP}$) in contactor off-gas, to as high as 15 percent by weight ($200 \text{ g/m}^3 \text{ NTP}$) in the ozone generator output.

Analytical methods for monitoring gas-phase ozone include:

- UV absorption;
- Iodometric methods;
- Chemiluminescence; and
- Gas-Phase titration.

Table 3-10 presents the working range, expected accuracy and precision, operator skill level required, interferences, and current status for gas phase ozone analysis.

3.5.1.1 UV Absorption

Gaseous ozone absorbs light in the short UV wavelength region with a maximum absorbance at 253.7 nm (Gordon et al., 1992). Instruments for measuring ozone by the absorption of UV radiation are supplied by several manufacturers for gas concentrations below 0.5 ppm by volume ($1 \text{ g/m}^3 \text{ NTP}$). In general, these instruments measure the amount of light absorptions when no ozone is present and the amount of light absorptions when ozone is present. The meter output is the difference of the two readings, which is directly related to the actual amount of ozone present. The International Ozone Association (IOA) has accepted this procedure (IOA, 1989).

Table 3-10. Characteristics and Comparisons of Gas-Phase Ozone Analytical Methods

Type of Test	Working Range (mg/L)	Expected Accuracy (± %)	Expected Precision (± %)	Skill Level ^a	Interferences	pH Range	Field Test	Automated Test	Current Status
UV Absorption	0.5 - 50,000	2	2.5	1/2	None	NA	Yes	Yes	Recommended
Stripping Absorption Iodometry	0.5 - 100	1 - 35	1 - 2	2	SO ₂ , NO ₂	NA	Yes	No	Not Recommended
Chemiluminescence	0.005 - 1	7	5	1/2	None	NA	Yes	Yes	Recommended
Gas-Phase Titration	0.005 - 30	8	8.5	2	None	NA	Yes	No	Not Recommended

Source: Gordon et al., 1992.

Notes: ^a Operator Skill Levels: 1 = minimal, 2 = good technician, 3 = experienced chemist. NA = Not Applicable

3.5.1.2 Iodometric Methods

Iodometric procedures have been used for all of the ozone concentration ranges encountered in water treatment plants (Gordon et al., 1992). This includes measurement of ozone directly from the generator and of ozone as stripped from aqueous solution. For the iodometric method, the ozone-containing gas is passed into an aqueous solution containing excess potassium iodide.

All other oxidizing materials act as interferences with iodometry (Gordon et al., 1992). Nitrogen oxides (that may be present when ozone is generated in air) also act as interferences to iodometric methods. The effects of nitrogen oxides may be eliminated by passing the ozone-containing gas through absorbents such as potassium permanganate that are specific for nitrogen oxide gases. However, no iodometric method is recommended for the determination of ozone in solution because of the unreliability of the method (Gordon et al., 1989).

3.5.1.3 Chemiluminescence

Chemiluminescence methods can be used for the determination of low concentrations of ozone in the gas phase (Gordon et al., 1992). One of the most commonly used methods is ethylene chemiluminescence. Gas-phase ozone can be measured using the chemiluminescent reaction between ethylene and ozone. This method is specific to ozone and is suitable for measurement of ozone in the ambient air. The ethylene chemiluminescence procedure was adopted in 1985 by the EPA as its reference method for determining ozone in the ambient atmosphere (McKee et al., 1975). Chemiluminescent instruments are approved by the EPA for monitoring ambient ozone concentrations of 0 to 0.5 or 0 to 1.0 ppm by volume. With regular calibration, this type of instrument is capable of providing reliable analysis of any ozone in the ambient air from an ozonation plant.

An alternative to ethylene chemiluminescence is rhodamine B/gallic acid chemiluminescence, which avoids the handling of ethylene (Gordon et al., 1992). This alternative method is considerably more complex than the more common ethylene chemiluminescence instruments. The sensitivity of this method tends to drift and a procedure has been developed by which corrections are made for the sensitivity on a frequent basis (Van Dijk and Falkenberg, 1977). Given the wide availability of ethylene chemiluminescence monitors and their approval by EPA, ethylene monitors should be considered before rhodamine B/gallic acid monitors.

3.5.1.4 Gas-Phase Titration

Two gas-phase titration methods have been studied as possible calibration methods for ambient ozone analyzers and monitors (Gordon et al., 1992). These procedures are based on titration with nitric oxide and back titration of excess nitric oxide (Rehme et al., 1980). These gas phase titration procedures, evaluated by EPA, were compared with UV absorption and iodometry as calibration methods for ethylene chemiluminescent ambient air ozone analyzers. As a result of these comparisons, UV absorption has been specified as the method of calibration for ambient ozone

analyzers. Therefore, gas-phase titration methods are not recommended for use at ozonation facilities (Gordon et al., 1992).

3.5.2 Monitoring of Liquid Phase Residual Ozone

There are numerous methods for monitoring ozone in aqueous solutions. Gordon et al. (1992) recommended the following methods for analyzing residual ozone:

- Indigo colorimetric method;
- Acid chrome violet K (ACVK) method;
- Bis-(Terpyridine) iron(II) method; and
- Stripping into the gas-phase.

Table 3-11 shows the working range, expected accuracy and precision, operator skill level required, interferences and current status for liquid phase residual ozone analytical methods.

3.5.2.1 Indigo Colorimetric Method

The indigo colorimetric method is the only method for monitoring residual ozone in *Standard Methods*, 1995. The indigo colorimetric method is sensitive, precise, fast, and more selective for ozone than other methods. There are two indigo colorimetric methods: spectrophotometric and visual. For the spectrophotometric procedure the lower limit of detection is 2 µg/L, while for the visual procedure the detection limit is 10 µg/L.

Hydrogen peroxide, chlorine, manganese ions, ozone decomposition products, and the products of organic ozonation exhibit less interference with the indigo colorimetric method than any of the other methods (Langlais et al., 1991). However, the masking of chlorine in the presence of ozone can make the indigo method problematic. In the presence of hypobromous acid, which forms during ozonation of bromide-ion containing methods, an accurate measurement cannot be made with this method (Standard Methods, 1995).

Table 3-11. Characteristics and Comparisons of Residual Ozone Analytical Methods

Type of Test	Working Range (mg/L)	Expected Accuracy (\pm %)	Expected Precision (\pm %)	Skill Level ^a	Interferences	pH Range	Field Test	Automated Test	Current Status
Indigo Colorimetric, Spectrophotometric	0.01 - > 0.3	1	0.5	1	Chlorine, Manganese ions, Bromine, Iodine	2	No	Yes	Recommended
Indigo Colorimetric, Visual	0.01 - > 0.1	1	0.5	1	Chlorine, Manganese ions, Bromine, Iodine	2	No	Yes	Recommended
ACVK	0.05 - 1	NR	NR	1	Manganese ions > 1 mg/L, Chlorine > 10 mg/L	2	No	No	Recommended
Bis-(Terpyridine) Iron(II)	0.05 - 20	2.7	2.1	3	Chlorine	< 7	No	Yes	Recommended Lab Test

Source: Gordon et al., 1992.

Notes: ^a Operator Skill Levels: 1 = minimal, 2 = good technician, 3 = experienced chemist. NR = Not reported in literature cited by referenced source.

3.5.2.2 ACVK Method

ACVK is readily bleached by ozone, which serves as the basis for this spectrophotometric procedure first reported by Masschelein (1977). The procedure has been developed further for the measurement of ozone in the presence of chlorine (Ward and Larder, 1973).

The advantages of this method (Langlais et al., 1991) are:

- Its ease of execution and stability of the dye reagent solution;
- A linear calibration curve over the range of 0.05 to 1.0 mg/L of ozone; and
- The apparent lack of interferences from low levels of manganese, chlorine or combined chlorine (up to 10 mg/L), organic peroxides, and other organic oxidation products.

3.5.2.3 Bis-(Terpyridine)Iron(II) Method

Bis-(Terpyridine)Iron(II) in dilute hydrochloric acid solution reacts with ozone to change the absorbance spectra measured at 552 nm (Tomiyasu and Gordon, 1984). The only known interferent is chlorine. However, chlorine interferences can be masked by the addition of malonic acid. Alternatively, since the reaction between chlorine and the reagent is slower than the reaction with ozone, the spectrophotometric measurements can be carried out immediately after reagent mixing to reduce the chlorine interference. Chlorine dioxide does not interfere (Gordon et al, 1992).

The primary advantages of the Bis-(Terpyridine)Iron(II) Method are its lack of interferences, low limits of detection (4 µg/L), broad working range (up to 20 mg/L), excellent reproducibility, and agreement with the indigo colorimetric method.

3.5.2.4 Stripping into the Gas-Phase

In this indirect procedure, residual ozone is stripped from the solution using an inert gas. The amount of ozone present in the gas phase is then analyzed by gas-phase analytical methods such as UV absorption or chemiluminescence described previously. This stripping technique was developed to minimize the complications caused by the presence of other oxidants in solution.

The success of this procedure initially depends upon the ability to strip ozone from the treated water without any decomposition. Since stripping conditions such as temperature, pH, and salinity can vary, the reliability of this method is suspect (Langlais et al., 1991).

3.5.3 Bromate Monitoring for Systems Using Ozone

The DBPR requires that community water systems and non-transient non-community water systems that use ozone for disinfection or oxidation must monitor their system for bromate. These systems are required to take one sample per month for each treatment plant with samples collected at the entrance to the distribution system while the ozonation system is operating under normal conditions.

The DBPR provides reduced monitoring opportunities (i.e., quarterly rather than monthly samples) if the system demonstrates that the average source water bromide concentration is less than 0.05 mg/L based upon representative monthly bromide measurements for one year. Systems can remain on the reduced monitoring schedule until the running annual average source water bromide concentration, computed quarterly, is equal to or greater than 0.05 mg/L based upon representative monthly measurements.

For compliance monitoring for bromate, systems must use the ion chromatography analytical method as specified in *USEPA Method 300.1, Determination of Inorganic Anions in Drinking Water by Ion Chromatography, Revision 1.0* (USEPA, 1997).

If the average of samples covering any consecutive four-quarter period exceeds the MCL, the system is in violation of the MCL and must notify the public pursuant to 40 CFR §141.32. The system must also report to the State pursuant to 40 CFR §141.134. If the system fails to complete 12 consecutive months' monitoring, compliance with the MCL for the last four-quarter compliance period must be based on an average of the available data.

3.6 Operational Considerations

3.6.1 Process Considerations

Because ozone is such a strong oxidant, it will react with many organic and inorganic compounds present in the water. Ozone is used to remove tastes and odors by breaking down organic compounds, and to aid in the removal of iron and manganese by oxidizing these compounds to less soluble forms. These demands should be satisfied before any ozone is available to satisfy primary disinfection requirements. The presence and concentration of these compounds can dictate the location of ozone addition, depending on the process goals.

Stolarik and Christie (1997) present the results of 10 years of operation at the 600 mgd Los Angeles Aqueduct Filtration and Ozone Facility. Operational experiences at this facility showed lower particle counts (greater than one micron) with ozone use. The optimum ozone concentration in the gas phase applied was found to be 6 percent when using the cryogenic oxygen production facilities, and 4 to 5 percent when using liquid oxygen (LOX).

3.6.2 Space Requirements

Storage of LOX is subject to regulations in building and fire codes. These regulations will impact the space requirements and may dictate the construction materials of adjacent structures if the certain setback requirements cannot be met. In general, the footprint for ozone generated from air is smaller than that required for chloramination and chloride dioxide applications. However, the footprint area for ozone generated from pure oxygen is comparable to that of chlorine dioxide because of the additional area needed for storage.

3.6.3 Material Selection

Ozone-resistant materials should be used from the ozone generators through the off-gas destruct unit. If oxygen is used for the feed gas, oxygen resistant materials should be used up to the generators. Pure oxygen piping should be specially cleaned after installation for oxygen service, which increases construction cost. Materials for air preparation systems can be those normally used for compressed air systems. Langlais et al. (1991) recommended that piping beyond the desiccant dryers be ozone-resistant, as some backflow and ozone diffusion can occur. If a receiver is provided following the desiccant dryer, the piping should be ozone-resistant, downstream of the pressure regulator. Ozone-resistant (oxygen resistant as well if high purity oxygen is the feed gas) check valves should be placed in the piping ahead of the generator.

Ozone-resistant materials include the austenitic (300 series) stainless steels, glass and other ceramics, Teflon and Hypalon, and concrete. The 304 series stainless steels can be used for “dry” ozone gas (also for oxygen), 316 series should be used for “wet” service. Wet service includes piping in the contactors and all off-gas piping and the off-gas destruct unit. Teflon or Hypalon should be used for gasket materials. Concrete should be manufactured from Type II or Type IV cement. Typical practice in the United States is to provide 3 inches of cover for reinforcing to prevent corrosion by either ozone gas or ozone in solution, although Fonlupt (1979) reports that 4 cm (1.13 inches) is adequate for protection. Hatches for access into contactors should be fabricated from 316 series stainless steels and provided with ozone-resistant seals.

3.6.4 Ozone System Maintenance

Stolarik and Christie (1997) provide a good overview of the operational and maintenance requirements during the 10 years of operating the 600 mgd Los Angeles Aqueduct Filtration and Ozone Plant. The ozone system has been available 97.1 percent of the time over the 10 year period.

Fuse failure and generator cleaning comprised the major maintenance chores on the ozone generators during the first years. Fuse failure was caused by a malfunction when its glass dielectric tube failed. Vessels are cleaned every three years or when exit gas temperatures rise due to Fe_3O_4 deposits on the ground electrode/heat exchanger surfaces.

Rod shaped ceramic diffusers worked well as ozone diffusers for the initial two years. These were replaced by sintered stainless steel and ultimately a modified ceramic diffuser.

3.6.5 Ozone Safety

Concern for safety even at the risk of being overcautious, would be to follow practices that have been successfully applied to other oxidants over the years. This would be to generally isolate the ozonation system from the remainder of the plant. This should not be interpreted to mean a separate building, but rather separate rooms, separate exterior entrances, separate heating and ventilation systems, noise control, etc. This method already is manifested in some of the European ozonation plants, but on a lesser scale.

Ozone generators should be housed indoors for protection from the environment and to protect personnel from leaking ozone in the case of a malfunction. Ventilation should be provided to prevent excess temperature rise in the generator room, and to exhaust the room in the case of a leak.

Adequate space should be provided to remove the tubes from the generator shell and to service the generator power supplies. Air prep systems tend to be noisy; therefore, it is desirable to separate them from the ozone generators. Off-gas destruct units can be located outside if the climate is not too extreme. If placed inside, an ambient ozone detector should be provided in the enclosure. All rooms should be properly ventilated, heated, and cooled to match the equipment-operating environment.

Continuous monitoring instruments should be maintained to monitor levels of ozone in the rooms. Self-contained breathing apparatuses should be located in hallways outside the rooms liable to ozone hazards. Ambient ozone exposure levels, which have been proposed by appropriate U.S. organizations, are summarized below. The maximum recommended ozone levels are as follows:

- **Occupational Safety and Health Administration.** The maximum permissible exposure to airborne concentrations of ozone not in excess of 0.1 mg/L (by volume) averaged over an eight-hour work shift.
- **American National Standards Institute/American Society for testing Materials (ANSI/ASTM).** Control occupational exposure such that the worker will not be exposed to ozone concentrations in excess of a time weighted average of 0.1 mg/L (by volume) for eight hours or more per workday, and that no worker be exposed to a ceiling concentration of ozone in excess of 0.3 mg/L (by volume) for more than ten minutes.
- **American Conference of Government Industrial Hygienists (ACGIH).** Maximum ozone level of 0.1 mg/L (by volume) for a normal eight hour work day or 40 hour work week, and a maximum concentration of 0.3 mg/L (by volume) for exposure of up to 15 minutes.
- **American Industrial Hygiene Association.** Maximum, concentration for eight hour exposure of 0.1 mg/L (by volume).

There is a question of whether prolonged exposure to ozone may impair a worker's ability to smell or be aware of ozone levels at less than critical levels. Awareness of an odor of ozone should not be relied upon. Instrumentation and equipment should be provided to measure ambient ozone levels and perform the following safety functions:

- Initiate an alarm signal at an ambient ozone level of 0.1 mg/L (by volume). Alarms should include warning lights in the main control panel and at entrances to the ozonation facilities as well as audible alarms.
- Initiate a second alarm signal at ambient ozone levels of 0.3 mg/L (by volume). This signal would immediately shut down ozone generation equipment and would initiate a second set of visual and audible alarms at the control panel and at the ozone generation facility entrances. An

emergency ventilation system capable of exhausting the room within a period of 2 to 3 minutes also would be interconnected to the 0.3 mg/L ozone level alarm.

Ozone gas is a hazardous gas and should be handled accordingly. Ambient ozone levels should be monitored and equipment shut-down and alarmed when levels exceed 0.1 ppm. Emergency ventilation is typically provided for enclosed areas. Building and fire codes will provide additional guidance. The OSHA exposure limit for an 8-hour shift is 0.1 ppm by volume. The pungent odor of ozone will provide warning to operators of any possible ozone leak.

3.7 Summary

3.7.1 Advantages and Disadvantages of Ozone Use

The following list highlights selected advantages and disadvantages of using ozone as a disinfection method for drinking water (Masschelein, 1992). Because of the wide variation of system size, water quality, and dosages applied, some of these advantages and disadvantages may not apply to a particular system.

Advantages

- Ozone is more effective than chlorine, chloramines, and chlorine dioxide for inactivation of viruses, *Cryptosporidium*, and *Giardia*.
- Ozone oxidizes iron, manganese, and sulfides.
- Ozone can sometimes enhance the clarification process and turbidity removal.
- Ozone controls color, taste, and odors.
- One of the most efficient chemical disinfectants, ozone requires a very short contact time.
- In the absence of bromide, halogen-substituted DBPs are not formed.
- Upon decomposition, the only residual is dissolved oxygen.
- Biocidal activity is not influenced by pH.

Disadvantages

- DBPs are formed, particularly by bromate and bromine-substituted DBPs, in the presence of bromide, aldehydes, ketones, etc.
- The initial cost of ozonation equipment is high.
- The generation of ozone requires high energy and should be generated on-site.
- Ozone is highly corrosive and toxic.
- Biologically activated filters are needed for removing assimilable organic carbon and biodegradable DBPs.
- Ozone decays rapidly at high pH and warm temperatures.
- Ozone provides no residual.

- Ozone requires higher level of maintenance and operator skill.

3.7.2 Summary Table

Table 3-12 presents a summary of the considerations for the use of ozone as a disinfectant.

Table 3-12. Summary of Ozone Disinfection Considerations

Consideration	Description
Generation	Because of its instability, ozone should be generated at the point of use. Ozone can be generated from oxygen present in air or high purity oxygen. The feed gas source should be clean and dry, with a maximum dewpoint of -60°C. Ozone generation consumes power at a rate of 8 to 17 kWhr/kg O ₃ . Onsite generation saves a lot of storage space.
Primary uses	Primary uses include primary disinfection and chemical oxidation. As an oxidizing agent, ozone can be used to increase the biodegradability of organic compounds destroys taste and odor control, and reduce levels of chlorination DBP precursors. Ozone should not be used for secondary disinfection because it is highly reactive and does not maintain an appreciable residual level for the length of time desired in the distribution system.
Inactivation efficiency	Ozone is one of the most potent and effective germicide used in water treatment. It is effective against bacteria, viruses, and protozoan cysts. Inactivation efficiency for bacteria and viruses is not affected by pH; at pH levels between 6 and 9. As water temperature increases, ozone disinfection efficiency increases.
Byproduct formation	Ozone itself does not form halogenated DBPs; however, if bromide ion is present in the raw water or if chlorine is added as a secondary disinfectant, halogenated DBPs, including bromate ion may be formed. Other ozonation byproducts include organic acids and aldehydes.
Limitations	Ozone generation is a relatively complex process. Storage of LOX (if oxygen is to be the feed gas) is subject to building and fire codes.
Points of application	For primary disinfection, ozone addition should be prior to biofiltration/filtration and after sedimentation. For oxidation, ozone addition can be prior to coagulation/sedimentation or filtration depending on the constituents to be oxidized.
Safety considerations	Ozone is a toxic gas and the ozone production and application facilities should be designed to generate, apply, and control this gas, so as to protect plant personnel. Ambient ozone levels in plant facilities should be monitored continuously.

3.8 References

1. Alceon Corp. 1993. Overview of Available Information on the Toxicity of Drinking Water Disinfectants and Their By-products. Cambridge, MA.
2. Amy, G.L., M.S. Siddiqui. 1991. "Ozone-Bromide Interactions in Water Treatment." Conference proceedings, AWWA Annual Conference, Philadelphia, PA.
3. AWWA (American Water Works Association). 1990. *Water Quality and Treatment*. F.W. Pontius (editor), McGraw-Hill, New York, NY.
4. Bablon, G.P., C. Ventresque, R.B. Aim. 1988. "Developing a Sand-GAC Filter to Achieve High Rate Biological Filtration." *J. AWWA*.80(12):47.
5. Bablon, G., et al. 1991. "Practical Application of Ozone: Principles and Case Studies." *Ozone in Water Treatment Application and Engineering*. AWWARF.
6. Billen, G., et al. 1985. Action des Populations Bactériennes Vis-à-Vis des Matières Organiques dans les Filtres Biologiques. Report to Compagnie Générale des Eaux, Paris.
7. Boyce, D.S., et al. 1981. "The Effect of Bentonite Clay on Ozone Disinfection of Bacteria and Viruses in Water." *Water Res.* 15:759-767.
8. Bringmann, G. 1954. "Determination of the Lethal Activity of Chlorine and Ozone on *E. coli*." *Z. f., Hygiene*. 139:130-139.
9. Chang, S.L. 1971. "Modern Concept of Disinfection." *J. Sanit. Engin. Division*. 97:689-707.
10. Cronholm, L.S., et al. 1976. "Enteric Virus Survival in Package Plants and the Upgrading of the Small Treatment Plants Using Ozone." Research Report No. 98, Water Resources Research Institute, University of Kentucky, Lexington, KY.
11. DeMers, L.D. and R.C. Renner. 1992. *Alternative Disinfection Technologies for Small Drinking Water Systems*. AWWARF and AWWA, Denver, CO.
12. Dimitriou, M.A. (editor). 1990. *Design Guidance Manual for Ozone Systems*. International Ozone Association, Norwalk, CN.
13. Domingue, E. L., et al. 1988. "Effects of Three Oxidizing Biocides on *Legionella pneumophila*, Serogroup 1." *Appl. Environ. Microbiol.* 40:11-30.
14. Eighmy, T.T., S.K. Spanos, J. Royce, M.R. Collins, J.P. Malley. 1991. "Microbial Activity in Slow Sand Filters." Conference proceedings, Slow Sand Filtration Workshop, Timeless Technology for Modern Applications, Durham, NH.

15. Farooq, S. et al. 1977. "The Effect of Ozone Bubbles on Disinfection." *Progr. Water Ozone Sci. Eng.* 9(2):233.
16. Farooq, S. 1976. *Kinetics of Inactivation of Yeasts and Acid-Fast Organisms with Ozone*. Ph.D. Thesis, University of Illinois at Urbana-Champaign, IL.
17. Farvardin, M.R. and A.G. Collins. 1990. "Mechanism(s) of Ozone Induced Coagulation of Organic Colloids." Conference proceedings, AWWA Annual Conference, Cincinnati, OH.
18. Finch, G. R., E.K. Black, and L.L. Gyürék. 1994. "Ozone and Chlorine Inactivation of *Cryptosporidium*." Conference proceedings, Water Quality Technology Conference, Part II, San Francisco, CA.
19. Franson, M.H., Eaton, A.D., Clesceri, L.S., and Greenberg, A.E., (editors). 1995. *Standard Methods for the Examination of Water and Wastewater, Nineteenth Edition*. American Public Health Association, AWWA, and Water Environment Federation, Washington D.C.
20. Georgeson, D.L. and A.A. Karimi. 1988. "Water Quality Improvements with the Use of Ozone at the Los Angeles Water Treatment Plant." *Ozone Sci. Engrg.* 10(3):255-276.
21. Giese, A.C. and E. Christensen. 1954. "Effects of Ozone on Organisms." *Physiol. Zool.* 27:101.
22. Glaze W.H., M. Koga, D. Cancilla. 1989a. "Ozonation Byproducts. 2. Improvement of an Aqueous-Phase Derivatization Method for the Detection of Formaldehyde and Other Carbonyl Compounds Formed by the Ozonation of Drinking Water." *Environ. Sci. Technol.* 23(7):838.
23. Glaze, W.H., M. Koga M., D. Cancilla, et al. 1989b. "Evaluation of Ozonation Byproducts from Two California Surface Waters." *J. AWWA.* 1(8):66.
24. Glaze, W.H., et al. 1987. "The Chemistry of Water Treatment Processes Involving Ozone, Hydrogen Peroxide, and Ultraviolet Radiation." *Ozone Sci. Engrg.* 9(4):335.
25. Glaze, W.H., and J.W. Kang. 1988. "Advanced Oxidation Processes for Treating Groundwater Contaminated with TCE and PCE: Laboratory Studies." *J. AWWA.* 88(5):57- 63.
26. Glaze, W.H., H.S. Weinberg, S.W. Krasner, M.J. Sclimenti. 1991. "Trends in Aldehyde Formation and Removal Through Plants Using Ozonation and Biological Active Filters." Conference proceedings, AWWA, Philadelphia, PA.
27. Goldstein, B.D., and E.M. McDonagh. 1975. "Effect of Ozone on Cell Membrane Protein Fluorescence I. *in vitro* Studies Utilizing the Red Cell Membrane." *Environ. Res.* 9:179-186.
28. Gordon, G. K. Rankness, D. Vornehm, and D. Wood. 1989. "Limitations of the Iodometric Determination of Ozone." *J. AWWA.* 81(6):72-76.
29. Gordon, G., W.J. Cooper, R.G. Rice, and G.E. Pacey. 1992. *Disinfectant Residual Measurement Methods*, second edition. AWWARF and AWWA, Denver, CO.

30. Gurol, M.D. and M. Pidotella. 1983. "A Study of Ozone-Induced Coagulation." Conference proceedings, ASCE Environmental Engineering Division Specialty Conference. Allen Medine and Michael Anderson (editors), Boulder, CO.
31. Haag, W.R. and J. Hoigné. 1984. "Kinetics and Products of the Reactions of Ozone with Various Forms of Chlorine and Bromine in Water." *Ozone Sci. Engrg.* 6(2):103-14.
32. Hann, V.A. 1956. "Disinfection of Drinking Water with Ozone." *J. AWWA.* 48(10):1316.
33. Harakeh, M.S. and M. Butler. 1984. "Factors Influencing the Ozone Inactivation of Enteric Viruses in Effluent." *Ozone Sci. Engrg.* 6:235-243.
34. Hildebrand, D.J., A.F. Hess, P.B. Galant, and C.R. O'Melia. 1986. "Impact of Chlorine Dioxide and Ozone Preoxidation on Conventional Treatment and Direct Filtration Treatment Processes." Conference proceedings, AWWA Seminar on Ozonation: Recent Advances and Research Needs, Denver, CO.
35. Hoff, J.C. 1986. *Inactivation of Microbial Agents by Chemical Disinfectants*, U. S. Environmental Protection Agency, EPA/600/2-86/067.
36. Hoigné J. and H. Bader. 1976. Role of Hydroxyl Radical Reactions in Ozonation Processes in Aqueous Solutions, *Water Res.* 10: 377.
37. Hoigné J., and H. Bader. 1988. "The Formation of Trichloronitromethane (chloropicrin) and Chloroform in a Combined Ozonation/Chlorination Treatment of Drinking Water." *Water Res.* 22(3):313.
38. Hoigné J., and H. Bader. 1983b. "Rate Constants of Reaction of Ozone with Organic and Inorganic Compounds in Water - II. Dissociating Organic Compounds." *Water Res.* 17:185-194.
39. Hoigné J., and H. Bader. 1977. "The Role of Hydroxyl Radical Reactions in Ozonation Processes in Aqueous Solutions." *Water Res.* 10:377-386.
40. Hoigné J., and H. Bader. 1983a. "Rate Constants of Reaction of Ozone with Organic and Inorganic Compounds in Water - I. Non-dissociating Organic Compounds." *Water Res.* 17:173-183.
41. Hoigné, J. and Bader, H. 1975. Ozonation of Water: Role of Hydroxyl Radicals as Oxidizing Intermediates. *Science*, Vol. 190, pp. 782.
42. Huck, P.M., P.M. Fedorak, and W.B. Anderson. 1991. "Formation and Removal of Assimilable Organic Carbon During Biological Treatment." *J. AWWA.* 83(12):69-80.
43. IOA (International Ozone Association). 1989. *Photometric Measurement of Low Ozone Concentrations in the Gas Phase*. Standardisation Committee--Europe.

44. Katz, J. 1980. *Ozone and Chlorine Dioxide Technology for Disinfection of Drinking Water*. Noyes Data Corporation, Park Ridge, New Jersey.
45. Katzenelson, E., et al. 1974. "Inactivation Kinetics of Viruses and Bacteria in Water by Use of Ozone." *J. AWWA*. 66:725-729.
46. Keller, J.W., R.A. Morin, and T.J. Schaffernoth. 1974. "Ozone Disinfection Pilot Plants Studies at Laconia, New Hampshire." *J. AWWA*. 66:730.
47. Kim, C.K., et al. 1980. "Mechanism of Ozone Inactivation of Bacteriophage f2." *Appl. Environ. Microbiol.* 39:210-218.
48. Kinman, R.N. 1975. "Water and Wastewater Disinfection with Ozone: A Critical Review." *Crit. Rev. Environ. Contr.* 5:141-152.
49. Krasner, S.W., W.H. Glaze, H.S. Weinberg, et al. 1993. "Formation of Control of Bromate During Ozonation of Water Containing Bromide." *J. AWWA*. 85(5):62..
50. Krasner, S.W., et al. 1989. "The Occurrence of Disinfection By-products in US Drinking Water." *J. AWWA*.81(8):41.
51. Langlais, B., et al. 1990. "New Developments: Ozone in Water and Wastewater Treatment. The CT Value Concept for Evaluation of Disinfection Process Efficiency; Particular Case of Ozonation for Inactivation of Some Protozoa, Free-Living Amoeba and *Cryptosporidium*." Presented at the Int. Ozone Assn. Pan-American Conference, Shreveport, Louisiana, March 27-29.
52. Langlais, B., D.A. Reckhow, and D.R. Brink (editors). 1991. *Ozone in Drinking Water Treatment: Application and Engineering*. AWWARF and Lewis Publishers, Boca Raton, FL.
53. Langlais B. and D. Perrine. 1986. "Action of Ozone on Trophozoites and Free Amoeba Cysts, Whether Pathogenic of Not." *Ozone Sci. Engrg.* 8(3):187-198.
54. LeChevallier, M.W., W.C. Becker, P. Schorr, and R.G. Lee. 1992. "Evaluating the Performance of Biologically Active Rapid Filters." *J. AWWA*. 84(4):136-146.
55. LeLacheur, R.M., P.C. Singer, and M.J. Charles. 1991. "Disinfection By-products in New Jersey Drinking Waters." Conference proceedings, AWWA Annual Conference, Philadelphia, PA.
56. Logsdon, G.S., S. Foellmi, and B. Long. 1992. "Filtration Pilot Plant Studies for Greater Vancouver's Water Supply." Conference proceedings, AWWA Annual Conference, Vancouver, British Columbia.
57. Malley, J.P., T.T. Eighmy, M.R. Collins, J.A. Royce, and D.F. Morgan. 1993. "The True Performance and Microbiology of Ozone - Enhanced Biological Filtration." *J. AWWA*. 85(12):47-57.

58. Masschelein, W.J. 1992. "Unit Processes in Drinking Water Treatment." Marcel Decker D.C., New York , Brussels, Hong Kong.
59. Masschelein, W.J. 1977. "Spectrophotometric Determination of Residual Ozone in Water with ACVK." *J. AWWA*. 69:461-462.
60. McGuire, M.J., S.W. Krasner, and J. Gramith. 1990. Comments on Bromide Levels in State Project Water and Impacts on Control of Disinfection Byproducts Metropolitan Water District of Southern California.
61. McKee, H.C., R.E. Childers, and V.B. Parr 1975. *Collaborative Study of Reference Method for Measurement of Photochemical Oxidants in the Atmosphere*, EPA EPA-650/4-75-016, Washington, D.C. February.
62. McKnight A., and D.A. Reckhow. 1992. "Reactions of Ozonation Byproducts with Chlorine and Chloramines." Conference proceedings, AWWA Annual Conference, Vancouver, British Columbia.
63. MWDSC and JMM (Metropolitan Water District of Southern California and James M. Montgomery Consulting Engineers). 1992. "Pilot Scale Evaluation of Ozone and peroxone." AWWARF and AWWA, Denver, CO.
64. Morris, J.C. 1975. "Aspects of the Quantitative Assessment of Germicidal Efficiency." *Disinfection: Water and Wastewater*. J.D. Johnson (editor). Ann Arbor Science Publishers, Inc., Ann Arbor, MI.
65. Owens, J. H., et al. 1994. "Pilot-Scale Ozone Inactivation of *Cryptosporidium* and *Giardia*." Conference proceedings, Water Quality Technology Conference, Part II, San Francisco, CA.
66. Peeters, J. E. et al. 1989. "Effect of Disinfection of Drinking Water with Ozone or Chlorine Dioxide on Survival of *Cryptosporidium parvum* Oocysts." *Appl. Environ. Microbiol.* 55(6):1519-1522.
67. Perrine, D., et al. 1984. "Action d l'Ozone sur les Trophozoites d'Amibes Libres Pathogens ou Non." *Bull Soc.Frnac. Parasitol.* 3:81.
68. Prendiville, D.A. 1986. "Ozonation at the 900 cfs Los Angeles Water Purification Plant." *Ozone Sci. Engrg.* 8:77.
69. Price, M.L. 1994. *Ozone and Biological Treatment for DBP Control and Biological Stability*. AWWARF and AWWA, Denver, CO, pp. 252.
70. Rachwal, A.J., et al. 1988. "Advanced Techniques for Upgrading Large Scale Slow Sand Filters." *Slow Sand Filtration- Recent Developments in Water Treatment Technology*, Ellis Horwood Ltd, Chichester, U.K.

71. Reckhow, D.A., J.K. Edzwald, and J.E. Tobiason. 1993. "Ozone as an Aid to Coagulation and Filtration." AWWARF and AWWA, Denver, CO.
72. Reckhow, D.A., P.C.Singer, and R.R. Trussell. 1986. Ozone as a coagulant aid. Seminar proceedings, Ozonation, Recent Advances and Research Needs, AWWA Annual Conference, Denver, CO.
73. Reckhow, D.A., J.E. Tobiason, M.S. Switzenbaum, R. McEnroe, Y. Xie, X. Zhou, P. McLaughlin, and H.J. Dunn. 1992. "Control of Disinfection Byproducts and AOC by Pre-Ozonation and Biologically Active In-Line Direct Filtration." Conference proceedings, AWWA Annual Conference, Vancouver, British Columbia.
74. Regli, S., J.E. Comwell, X. Zhang., et al. 1992. *Framework for Decision Making: An EPA Perspective*. EPA 811-R-92-005, EPA, Washington, D.C.
75. Rehme, K.A., J.C. Puzak, M.E. Beard, C.F. Smith, and R.J. Paur. 1980. *Evaluation of Ozone Calibration Procedures*, EPA-600/S4-80-050, EPA, Washington, D.C, February.
76. Renner, R.C., M.C. Robson, G.W. Miller, and A.G. Hill. 1988. "Ozone in Water Treatment - The Designer's Role." *Ozone Sci. Engrg.* 10(1):55-87.
77. Rice, R.G. 1996. Ozone Reference Guide. Electric Power Research Institute, St. Louis, MO.
78. Rice, R.G., P.K. Overbeck, K. Larson. 1998. Ozone Treatment for Small Water Systems. Presented at the First International Symposium on Safe Drinking water in Small Systems. NSF International/PAHP/WHO, Arlington, VA, May 10-13, 1998.
79. Riesser, V.W., et al. 1976. "Possible Mechanisms of Poliovirus Inactivation by Ozone." *Forum on Ozone Disinfection*, E. G. Fochtman, R.G. Rice, and M.E. Browning (editors), pp. 186-192, International Ozone Institute, Syracuse, NY.
80. Rittman, B.E. 1990. "Analyzing Biofilm Processes Used in Biological Filtration." *J. AWWA.* 82(12):62.
81. Roy, D. 1979. *Inactivation of Enteroviruses by Ozone*. Ph.D. Thesis, University of Illinois at Urbana-Champaign.
82. Roy, D., R.S. Engelbrecht, and E.S.K. Chian. 1982. "Comparative Inactivation of Six Enteroviruses by Ozone." *J. AWWA.* 74(12):660.
83. Scott, D.B.M. and E.C. Leshner. 1963. "Effect of Ozone on Survival and Permeability of Escherichia coli." *J. Bacteriol.* 85:567-576.
84. Singer P.C. 1992. "Formation and Characterization of Disinfection Byproducts." Presented at the First International Conference on the Safety of Water Disinfection: Balancing Chemical and Microbial Risks.

85. Singer, P.C., et al. 1989. "Ozonation at Belle Glade, Florida: A Case History." Conference proceeding, IOA Ninth Ozone World Conference.
86. Song, R., et al. 1997. "Bromate Minimization During Ozonation." *J. AWWA*. 89(6):69.
87. Sproul, O. J., et al. 1982. "The Mechanism of Ozone Inactivation of Waterborne Viruses." *Water Sci. Technol.* 14:303-314.
88. Staehelin, J., R.E. Bühler, and J. Hoigné. 1984. "Ozone Decomposition in Water Studies by Pulse Radiolysis. 2 OH and HO₄ as Chain Intermediates." *J. Phys. Chem.* 88:5999-6004.
89. Stolarik, G. F., and J.D. Christie. 1997. "A Decade of Ozonation in Los Angeles." Conference proceedings, IOA Pan American Group Conference, Lake Tahoe, NV.
90. Suffet, I.H., C. Anselme, and J. Mallevalle. 1986. "Removal of Tastes and Odors by Ozonation." Conference proceedings, AWWA Seminar on Ozonation: Recent Advances and Research Needs, Denver, CO.
91. Tobiason, J.E., J.K. Edzwald, O.D. Schneider, M.B. Fox, and H.J. Dunn. 1992. "Pilot Study of the Effects of Ozone and Peroxone on In-Line Direct Filtration." *J. AWWA*. 84(12):72-84.
92. Tomiyasu, H., and G. Gordon. 1984. "Colorimetric Determination of Ozone in Water Based on Reaction with Bis-(terpyridine)iron(II)." *Analytical Chem.* 56:752-754.
93. Troyan, J.J. and S.P. Hansen. 1989. *Treatment of Microbial Contaminants in Potable Water Supplies Technologies and Costs*. Noyes Data Corporation, Park Ridge, New Jersey.
94. Umphries, M.D., et al. 1979. "The Effects of Pre-ozonation on the Formation of Trihalomethanes." *Ozonews*. 6(3).
95. USEPA. 1997. USEPA Method 300.1, Determination of Inorganic Anions in Drinking Water by Ion Chromatography, Revision 1.0. EPA A/600/r-98/118.
96. Van Dijk, J.F.M., and R.A. Falkenberg. 1977. "The Determination of Ozone Using the Reaction with Rhodamine B/Gallic Acid." Presented at Third Ozone World Congress sponsored by the IOA, Paris, France, May.
97. Van Gunten, U. and J. Hoigné. 1996. "Ozonation of Bromide-Containing Waters: Bromate Formation through Ozone and Hydroxyl Radicals." *Disinfection By-Products in Water Treatment*, Minear, R.A. and G.L. Amy (editors). CRC Press, Inc., Boca Raton, FL.
98. Van Hoof, F., J.G. Janssens, H. van Dijck. 1985. "Formation of Mutagenic Activity During Surface Water Pre-ozonation and Its Removal in Drinking Water Treatment." *Chemosphere*, 14(5):501.

99. Vaughn, J.M., et al. 1987. "Inactivation of Human and Simian Rotaviruses by Ozone." *Appl. Env. Microbiol.* 53:2218-2221.
100. Walsh, D.S., et al. 1980. "Ozone Inactivation of Flocc Associated Viruses and Bacteria." *J. Environ. Eng. Div. ASCE.* 106:711-726.
101. Ward, S.B. and D.W. Larder. 1973. "The Determination of Ozone in the Presence of Chlorine." *Water Treatment Examination.* 22:222-229.
102. Wickramanayake, G.B., et al. 1984b. "Inactivation of Giardia lamblia Cysts with Ozone." *Appl. Env. Microbiol.* 48(3):671-672.
103. Wickramanayake, G.B., et al. 1984a. "Inactivation of Naegleria and Giardia cysts in Water by Ozonation." *J. Water Pollution Control Fed.* 56(8):983-988.
104. Wickramanayake, G.B. 1984c. *Kinetics and Mechanism of Ozone Inactivation of Protozoan Cysts.* Ph.D. dissertation, Ohio State University, Columbus, OH.
105. Wuhrmann, K., and J. Meyrath. 1955. "The Bactericidal Action of Ozone Solution. *Schweitz.*" *J. Allgen. Pathol. Bakteriol.*, 18:1060.
106. Yamada, H. and I. Somiya. 1989. "The Determination of Carbonyl Compounds in Ozonated Water By the PFBOA Method." *Ozone Sci. Engrg.* 11(2):127.
107. Zabel, T.F. 1985. "The Application of Ozone for Water Treatment in the United Kingdom - Current Practice and Recent Research." *Ozone Sci. Engrg.* 7(1):11.

OZONE.....	3-1
3.1 OZONE CHEMISTRY	3-1
3.2 OZONE GENERATION	3-4
3.2.1 Ozone Production	3-4
3.2.2 System Components	3-5
3.2.3 Operation and Maintenance	3-15
3.3 PRIMARY USES AND POINTS OF APPLICATION OF OZONE	3-16
3.3.1 Primary Uses of Ozone	3-16
3.3.2 Points of Application	3-18
3.3.3 Impact on Other Treatment Processes	3-19
3.3.4 Biologically Active Filtration	3-19
3.3.5 Pathogen Inactivation and Disinfection Efficacy	3-21
3.3.6 Inactivation Mechanisms	3-22
3.3.7 Disinfection Parameters	3-22
3.3.8 Inactivation of Microorganisms	3-24
3.4 OZONATION DISINFECTION BYPRODUCTS	3-27
3.4.1 Ozone Byproduct Control	3-30
3.5 STATUS OF ANALYTICAL METHODS	3-31
3.5.1 Monitoring of Gas Phase Ozone	3-31
3.5.2 Monitoring of Liquid Phase Residual Ozone	3-35
3.5.3 Bromate Monitoring for Systems Using Ozone	3-37
3.6 OPERATIONAL CONSIDERATIONS	3-38
3.6.1 Process Considerations	3-38
3.6.2 Space Requirements	3-38
3.6.3 Material Selection	3-39
3.6.4 Ozone System Maintenance	3-39
3.6.5 Ozone Safety	3-39
3.7 SUMMARY	3-41
3.7.1 Advantages and Disadvantages of Ozone Use	3-41
3.7.2 Summary Table	3-42
3.8 REFERENCES	3-43
Table 3-1. Types of Compressors Used in Air Preparation Systems	3-7
Table 3-2. Comparison of Air and High Purity Oxygen Feed Systems	3-8
Table 3-3. Comparison of Primary Characteristics of Low, Medium, and High Frequency Ozone Generators	3-10
Table 3-4. Bubble Diffuser Contactor Advantages and Disadvantages	3-12
Table 3-5. Injection Contacting Advantages and Disadvantages	3-13
Table 3-6. Turbine Mixer Contactor Advantages and Disadvantages	3-14
Table 3-7. Criteria for Selecting Ozone Feed Points for Small Systems	3-18
Table 3-8. Summary of Reported Ozonation Requirements for 99 Percent Inactivation of <i>Cryptosporidium</i> Oocysts	3-27
Table 3-9. Principal Known Byproducts of Ozonation	3-28
Table 3-10. Characteristics and Comparisons of Gas-Phase Ozone Analytical Methods	3-33
Table 3-11. Characteristics and Comparisons of Residual Ozone Analytical Methods	3-36
Table 3-12. Summary of Ozone Disinfection Considerations	3-42
Figure 3-1. Oxidation Reactions of Compounds (Substrate) During Ozonation of Water	3-2
Figure 3-2. Reaction of Ozone and Bromide Ion Can Produce Bromate Ion and Brominated Organics	3-3
Figure 3-3. Basic Ozone Generator	3-4
Figure 3-5. Schematic of an Air Preparation System	3-7

Figure 3-6. Cylindrical Electrode Schematic	3-9
Figure 3-7. Ozone Bubble Contactor	3-11
Figure 3-8. Sidestream Ozone Injection System.....	3-12
Figure 3-9. Turbine Mixer Ozone Contactor	3-14
Figure 3-10. CT Values for Inactivation of Viruses by Ozone (pH 6 to 9)	3-26
Figure 3-11. Principal Reactions Producing Ozone Byproducts	3-28
Figure 3-12. Main Pathways of Bromate Ion Formation when Ozone Reacts with Bromide Ion	3-30