

# A look at ozone in hydroponics applications

A case study of how ozone can make a difference in tomato crop yield.

By Ted Rich and Ed Kneuve

The use of ozone for hydrogen sulfide removal is not uncommon; thousands of residential wells and small community drinking water systems rely on ozone technology to achieve a number of water treatment goals, including oxidation of other inorganic contaminants such as iron and manganese, disinfection and oxidation of organic micropollutants.

Just when you're certain you have heard of every possible water treatment scenario, along comes another.

This article profiles a hydroponic (See **side, What is hydroponics?**) operation in Northwest Ohio that supplies fresh winter tomatoes to local grocery stores and restaurants.

## Anatomy of the problem

Rejection rates had reached 40 percent (largely from a condition known as blossom end rot) and fertilizer use was inordinately high.

A complete water analysis was performed, revealing the culprits; the source water had a pH of 7.8, its Oxidation Reduction Potential (ORP) was an extremely low  $-177$  mV and it contained 60 parts per million (ppm) of hydrogen sulfide.

Based on the water analysis results, the grower and fertilizer supplier theorized that the hydrogen sulfide was blocking the fertilizer, prompting the excessive use of fertilizer and poor crop yields.

It was also believed that low

dissolved oxygen levels in the water contributed to limited plant growth and the blossom end rot was caused by the high pH.

Characterized by dime-sized brown spots, blossom end rot is the result of insufficient calcium in the flower end of the fruit. The grower believed that the bacteria feeding off the hydrogen sulfide was contributing to an extremely high organic load, which in turn was driving up the pH. The high pH condition was inhibiting the transfer of calcium from the water to the fruit.

## The water

The tomato plants grown in this two year-old hydroponics operation are

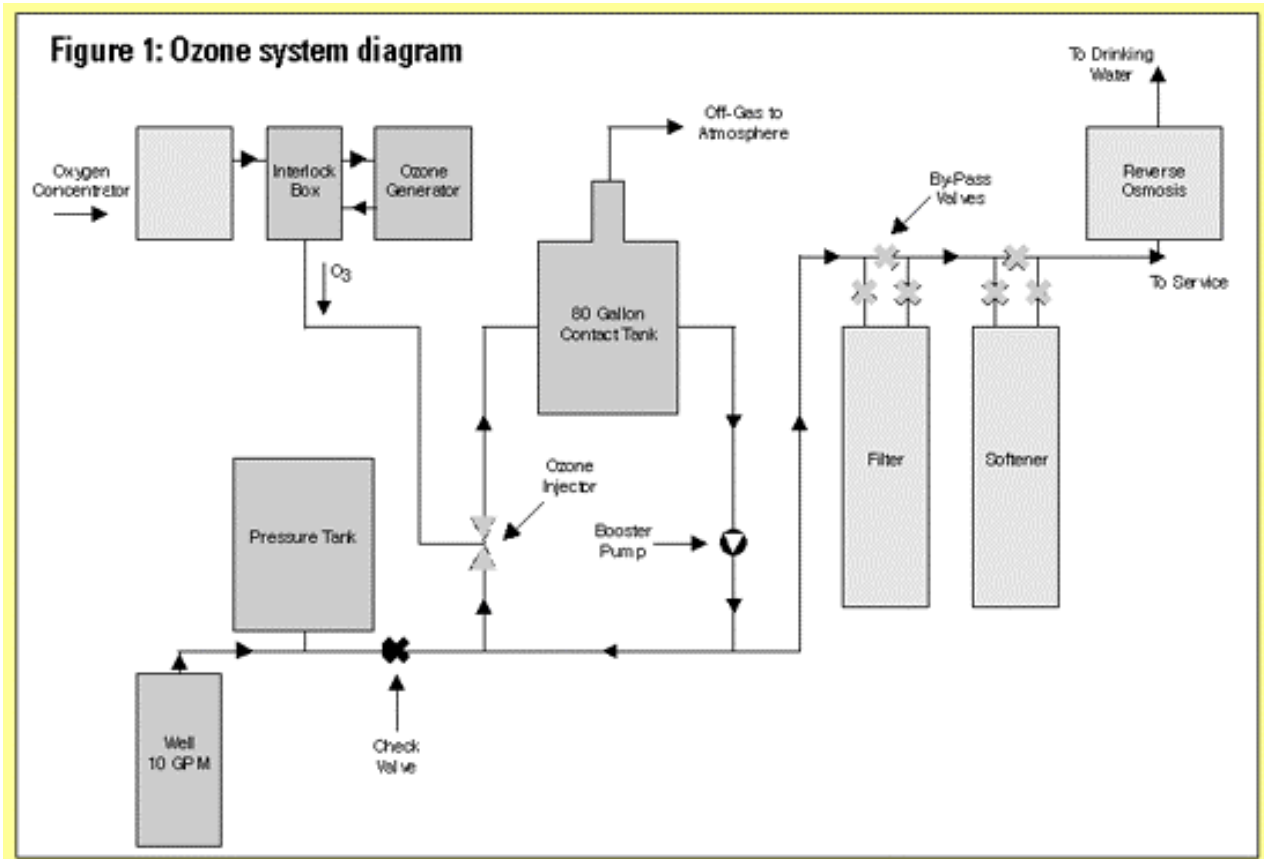

## What is hydroponics?

Hydroponics is a method for growing plants in a solution of water and fertilizers. The term comes from two words of Greek origin – “hydro” meaning “water” and “ponics” from the word “geoponic,” meaning “of or relating to agriculture or farming.”

Liquid hydroponic systems use nothing to support the plant roots, while aggregate systems employ some kind of inert, soil-less growing medium (such as baked clay stone, rockwool, coconut fiber, etc.).

Whether liquid or aggregate, water is the lifeline; all essential nutrients are carried to the plants by water.

To provide temperature control and to minimize evaporative water loss and pest infestation, most hydroponic operations are enclosed in greenhouses.

### Some advantages to hydroponic farming:

- Plants mature more rapidly (up to 30 percent) – because root systems are smaller;
- Higher density planting – minimizes use of land area;
- Allows for production in areas where suitable soil does not exist;
- Indifference to temperature/seasons;
- More efficient use of water and fertilizers; and
- No weeds or soil-borne diseases and pests.

Disadvantages include the energy costs associated with heating, cooling and lighting the greenhouses, and the high skill level required to manage a successful hydroponic operation.

Growth of hydroponic farming in the United States has been slow since interest in the technology for commercial use surfaced in the mid-1920s.

Developments in new production techniques and improved materials have since caused only temporary surges in its acceptance.

However, growers are once again establishing hydroponic farms, driven at least in part by environmental concerns for groundwater pollution from nutrient wastes and soil sterilizers.

— *T.R and E.K.*

housed in a single 40' x 60' greenhouse.

The source water comes from a 100' deep well pumped at 10 gallons per minute (gpm) into a pressure tank.

The drip system uses water continuously at two gpm, but peaks at eight gpm when chemical fertilizers are applied.

The fertilizer supplier was aware of some hydrogen sulfide in the water and had made several attempts to counteract its affect on fertilizer consumption.

However, the water itself had remained untreated prior to the ozone system installation.

### Why ozone?

The grower's water treatment dealer suggested the use of ozone technology because it could economically resolve a number of the treatment challenges posed by the source water.

Sixty ppm of hydrogen sulfide represented a serious problem in itself, and it could be traced to the root of other troubles. For example, water with high levels of hydrogen sulfide is oxygen-deficient, providing favorable conditions for the growth of anaerobic bacteria.

Also, water with low dissolved oxygen content does not allow for vigorous plant growth.

Ozone is effective for removing hydrogen sulfide without leaving chemical byproducts. At the same time, the dealer knew ozone could raise the ORP level of the water and provide disinfection through oxidation of organic contaminants.

Also, the use of an oxygen-fed ozone system would introduce higher levels of dissolved oxygen into the water. In addition to reducing the hydrogen sulfide level, the dissolved oxygen would help promote plant health and inhibit the proliferation of some waterborne anaerobic bacteria.

### Picking the right system

Using a sizing formula to compute ozone output requirements, the dealer determined that an air cooled, corona discharge ozone generator would produce the desired water treatment results.

The air preparation system supplying the ozone generator is a pressure swing adsorption (PSA) oxygen concentrator that produces 90 percent + oxygen at eight standard cubic feet per hour (SCFH).

At that flow rate, the ozone generator is producing 10 grams per hour at 5 percent concentration (by weight).

The ozone system also features an electrical interlock box, which allows the grower to monitor such critical functions as oxygen flow to the ozone generator and vacuum produced by the injector.

The interlock box also includes a stainless steel solenoid valve for positive backflow protection.

Raw water from the well flows at 10 gpm into the pressure tank. A flow switch - located downstream from the filter - triggers an off-delay timer, which starts the 3/4 horsepower, stainless steel ozone system booster pump (see Figure 1).

## The booster pump

This application is somewhat unique in that the booster pump is located downstream of the ozone injector/venturi rather than upstream. This allows the system to operate more efficiently by using a comparatively small booster pump to drive a larger venturi.

The booster pump actually pulls the water past the ozone injection point rather than the more common arrangement that has the pump pushing the water through the venturi.

The ozone system is plumbed in a side stream configuration. The booster pump pulls approximately 90 percent of the raw water from the pressure tank, through the ozone injector and into a 120-gallon contact tank.

Ozone is drawn into the water under vacuum, created by a pressure differential across the venturi. Water enters the venturi at 40 - 60 psi and leaves at 10 - 30 psi. From the contact tank, the ozonated water enters a tee, where a portion flows toward the filter and the remainder is recirculated past the ozone injection point and back to the contact tank.

**Figure 2: Comparison of pre- and post-treatment waters**

Operating parameter	Pre-treatment	Post-treatment
Hydrogen sulfide	60 ppm	0.0 ppm
PH	7.8	7.04
ORP	-177mV	+225mV
Crop rejection rate	40%	<3 %
Total crop yield	-	+300%
First harvest interval	-	-28 days
Fertilizer expense	-	-50%

With a recirculation rate of approximately 20 gpm and a use rate of 2 gpm, the water is allowed ample ozone contact time. The post-treatment filter is filled with two cubic feet of a proprietary mixed media.

### Results

It has been more than two years since the ozone system was installed and it continues to deliver positive results.

Figure 2 shows the very clear difference between the original raw water and the post-treatment water.

Hydrogen sulfide was eliminated completely – from 60 ppm to zero ppm.

The ozone system was able to dramatically reduce the organic load in the water, which had a direct influence on the water's pH (lowered from 7.8 to

7.04) and ORP ( raised from –177 mV to a +225 mV).

The significant changes to the overall water quality paved the way for vast improvements in crop production results.

Rejection rates of 40 percent were reduced to less than 3 percent and fertilizer costs have been cut by at least 50 percent.

The interval from planting to first harvest was shortened by 28 days, contributing to an impressive increase in total yield of more than 300 percent.

With improved yields and reduced operating costs, the grower's return on ozone system investment was just six months.